

**NOTES:**

1. FOR GRAVITY APPLICATIONS ONLY.
2. ALL GREEN TURTLE™ UNITS ARE MANUFACTURED WITH FIBERGLASS REINFORCED PLASTICS. PHYSICAL CHARACTERISTICS AND THICKNESS: POLYESTER RESIN AND E GLASS MINIMUM THICKNESS 1/4" WALL AND 3/8" TOP AND BOTTOM BOWLS.
3. ALL UNITS ARE TO BE INSTALLED IN ACCORDANCE WITH THE MANUFACTURERS INSTALLATION INSTRUCTION.
4. STANDARD PIPING IS SCHEDULE 40 PVC.
5. EHT 500 - 1500 UNITS COME STANDARD WITH 4" INLET (OTHER CUSTOM SIZES AVAILABLE ON REQUEST).
6. EXTENSION COLLAR TO BE ORDERED TO MEET FINISHED GRADE, CUT ON SITE FOR FINAL ADJUSTMENT AND CAULKED WITH SIKAFLEX BY CONTRACTOR FOR WATERTIGHT SEAL.
7. COVERS AVAILABLE FOR H2O TRAFFIC LOADING, PEDESTRIAN LOADING OR ABOVE GROUND INSTALLATION.
8. CONSULT GREEN TURTLE FOR OTHER SIZES.
9. 30 YEAR WARRANTY AGAINST LEAKS, AND STRUCTURAL FAILURE.
10. U.S. PATENT #5,746,912; CDN PATENT #2,195,822

**SPECIFICATIONS**

PIPE SIZE: 4 INCH PVC SCH 40  
 INSTALLATION: BURIED  
 ACCESSWAY SIZE: 24 INCHES

**OPTIONS**

STEEL LIFTING LUGS

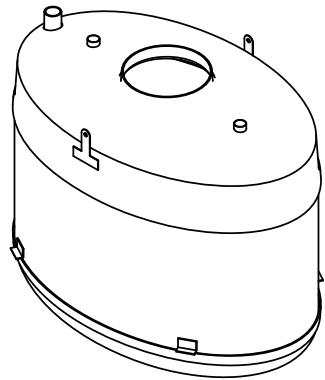

ISOMETRIC VIEW

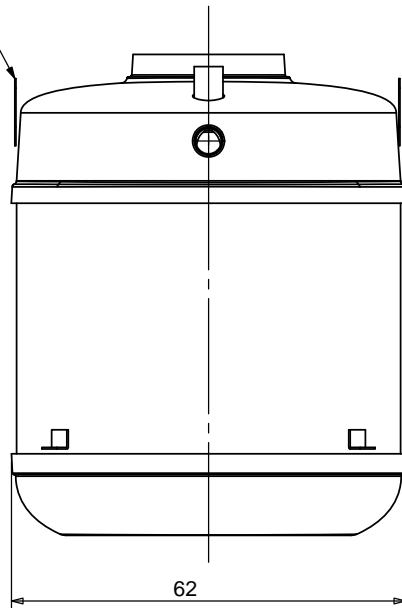

SIDE VIEW

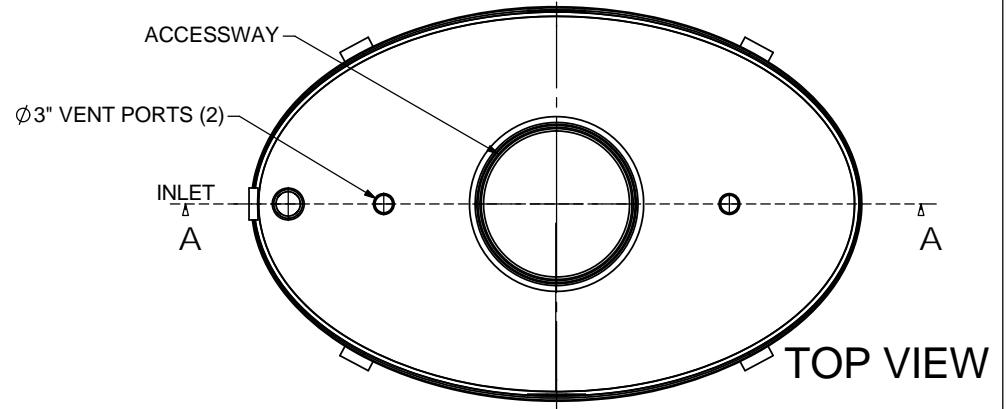

TOP VIEW

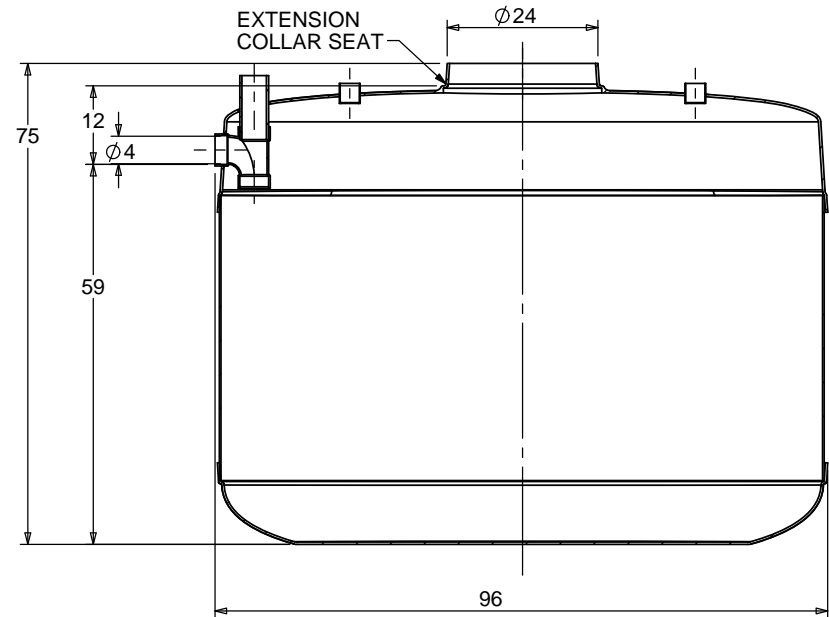

SECTION A-A

TITLE: <b>HOLDING TANK</b> EHT 1000 US GALLONS		REV	DATE	DRAWN	
ALL DIMENSIONS IN INCHES		1			
PROJECT: WO:		2	APRIL 18, 2013		
NOTES:		3	MARCH 08, 2017		
		4	APRIL 24, 2017		
		5			
		6			
		7			
		8			
		9			
		10			
DRAWN BY: L. SIMKINS		SIZE	DWG. NO.		REV.
DRAWN DATE: DEC. 10, 2009		A	EHT 1000		4
		SCALE:1:30	DO NOT SCALE DRAWING		SHEET 1 OF 1