

**NOTES:**

1. FOR GRAVITY APPLICATIONS ONLY.
2. ALL PROCEPTOR UNITS ARE MANUFACTURED WITH FIBERGLASS REINFORCED PLASTICS; PHYSICAL CHARACTERISTICS:  
ISOPHTHALIC POLYESTER RESIN WITH E GLASS.
3. ALL PROCEPTOR UNITS ARE TO BE INSTALLED IN ACCORDANCE WITH THE MANUFACTURERS INSTALLATION INSTRUCTION.
4. STANDARD PIPING IS SCH. 40 PVC.
5. GMC/OMC 4,000 - 10,000 UNITS COME STANDARD WITH 6" INLET AND OUTLET (OTHER CUSTOM SIZES AVAILABLE AT EXTRA CHARGE).
6. ADVISE GREEN TURTLE OF INVERT DEPTH; DEEP INSTALLATIONS MAY REQUIRE CUSTOM REINFORCEMENT.
7. EXTENSION COLLAR TO BE ORDERED TO MEET FINISHED GRADE.  
CUT ON SITE FOR FINAL ADJUSTMENT, AND CAULKED WITH SIKAFLEX BY CONTRACTOR FOR WATERTIGHT SEAL.
8. COVERS AVAILABLE FOR H2O TRAFFIC LOADING, PEDESTRIAN LOADING OR ABOVE GROUND INSTALLATION.
9. CONSULT GREEN TURTLE FOR OTHER SIZES.
10. 30 YEAR WARRANTY AGAINST LEAKS, AND STRUCTURAL FAILURE.
11. U.S. PATENT #5,746,912; CDN PATENT #2,195,822

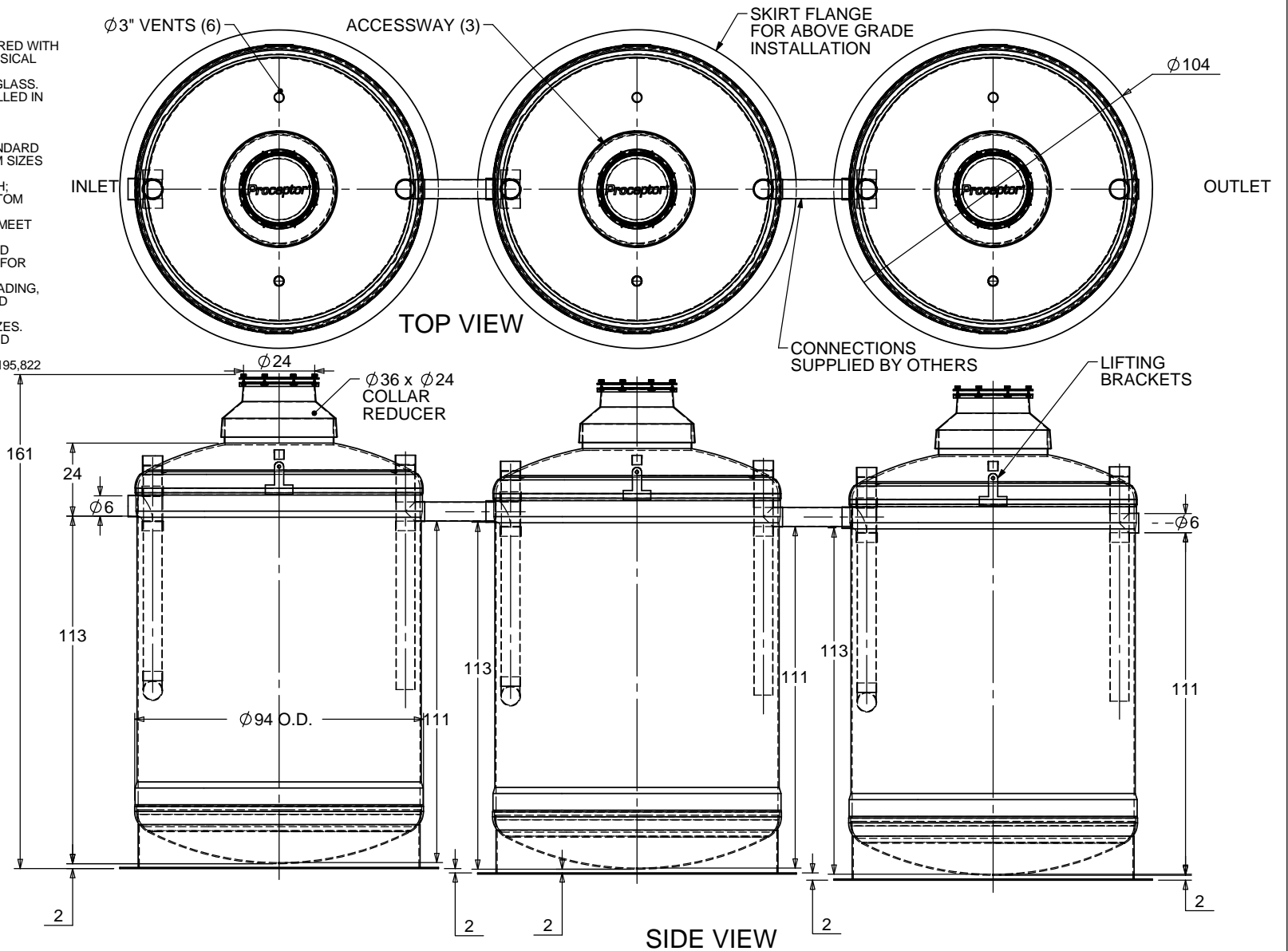

TOTAL WET VOLUME: 9000 GAL  
 MAX. OIL CAPACITY: 4324 GAL  
 MAX SOLIDS CAPACITY: 3139 GAL

CONSULT LOCAL AUTHORITIES FOR  
 MINIMUM SIZE OF SEPARATORS

TITLE: PROCEPTOR SEPARATOR  
 O MC 9000 GALLON INTERCEPTOR  
 6" INLET & OUTLET  
 36" ACCESSWAY  
 ALL DIMENSIONS IN INCHES

PROJECT: WO:

- AVAILABLE OPTIONS (CHECKED IF REQUESTED)
- OIL OR GREASE SENSOR ALARM
  - SUCTION PIPE FOR INDOOR INSTALLATION
  - ABOVE GROUND INSTALLATION

REV	DATE	DRAWN
1	JANUARY 8, 2008	L. SIMKINS
2	NOVEMBER 13, 2009	L. SIMKINS
3	APRIL 2, 2012	L. SIMKINS
4		
5		
6		
7		
8		
9		
10		

DRAWN BY: L. SIMKINS  
 DRAWN DATE: FEBRUARY 9, 2007

**Proceptor**®  
 by greenturtle®  
 US 877 428 8187 CAN 877 966 9444  
 www.greenturtletech.com

SIZE	DWG. NO.	REV.
A	OMC 9000(3)	3
SCALE:1:50	DO NOT SCALE DRAWING	SHEET 1 OF 1