

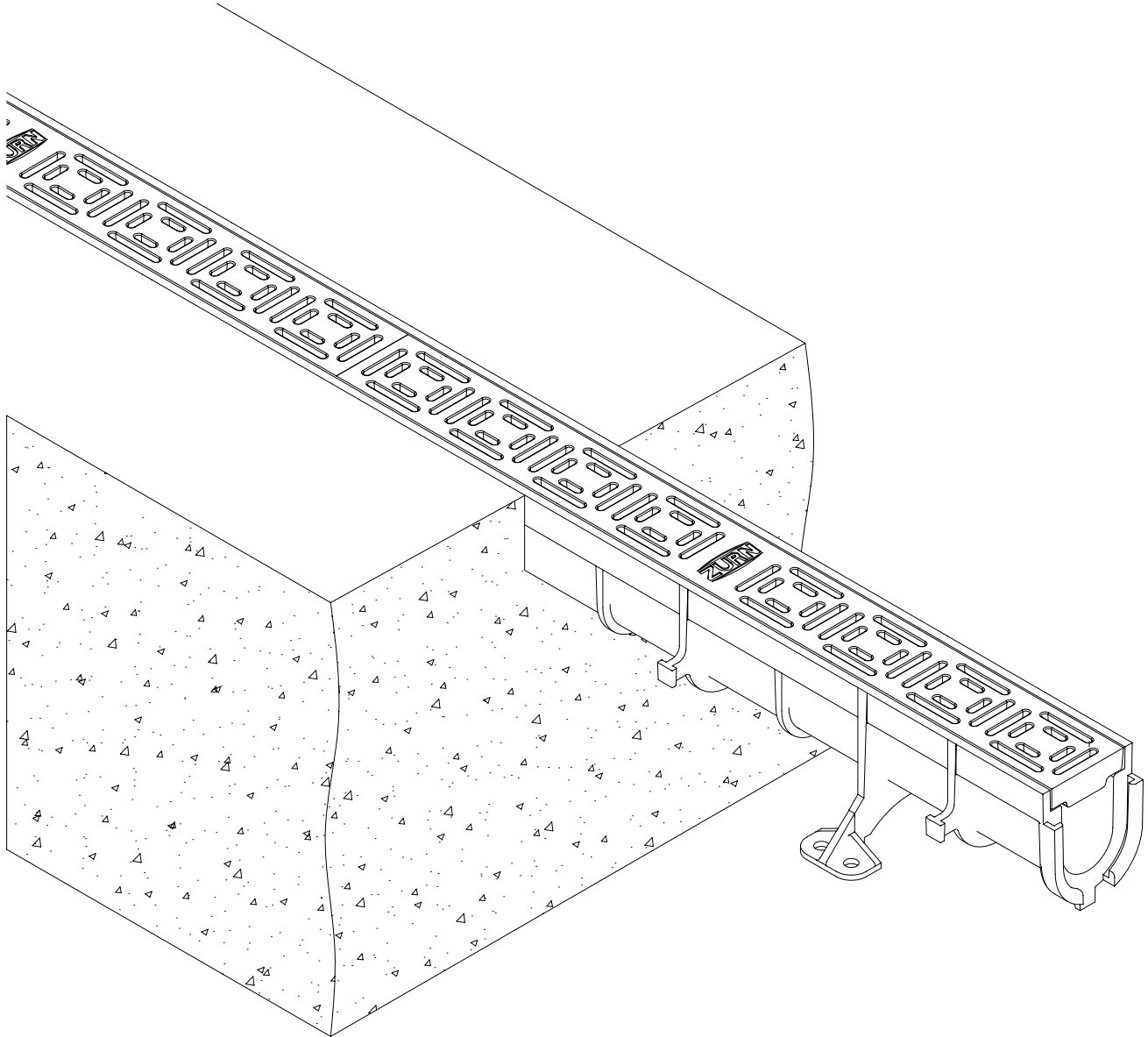

Z880

SHALLOW TRENCH DRAIN SYSTEM INSTALLATION INSTRUCTIONS

Design and Dimensional Data (inches and [mm]) are Subject to Manufacturing Tolerances and Change Without Notice



⚠ WARNING: Cancer and Reproductive Harm - www.P65Warnings.ca.gov

⚠ ADVERTENCIA: Cáncer y daño reproductivo - www.P65Warnings.ca.gov

⚠ AVERTISSEMENT: Cancer et effets néfastes sur la reproduction - www.P65Warnings.ca.gov

Zurn Industries, LLC | Specification Drainage Operation
1801 Pittsburgh Avenue, Erie, PA 16502, Ph. 855.663.9876

In Canada | Zurn Industries Limited
7900 Goreway Drive, Unit 10, Brampton, Ontario L6T 5W6, Ph. 877.892.5216

www.zurn.com

Rev. B
Date: 04/21/2022
C.N. No. 144452
Form No. FT902



Design and Dimensional Data (inches and [mm]) are Subject to Manufacturing Tolerances and Change Without Notice

Z880
TRENCH DRAIN

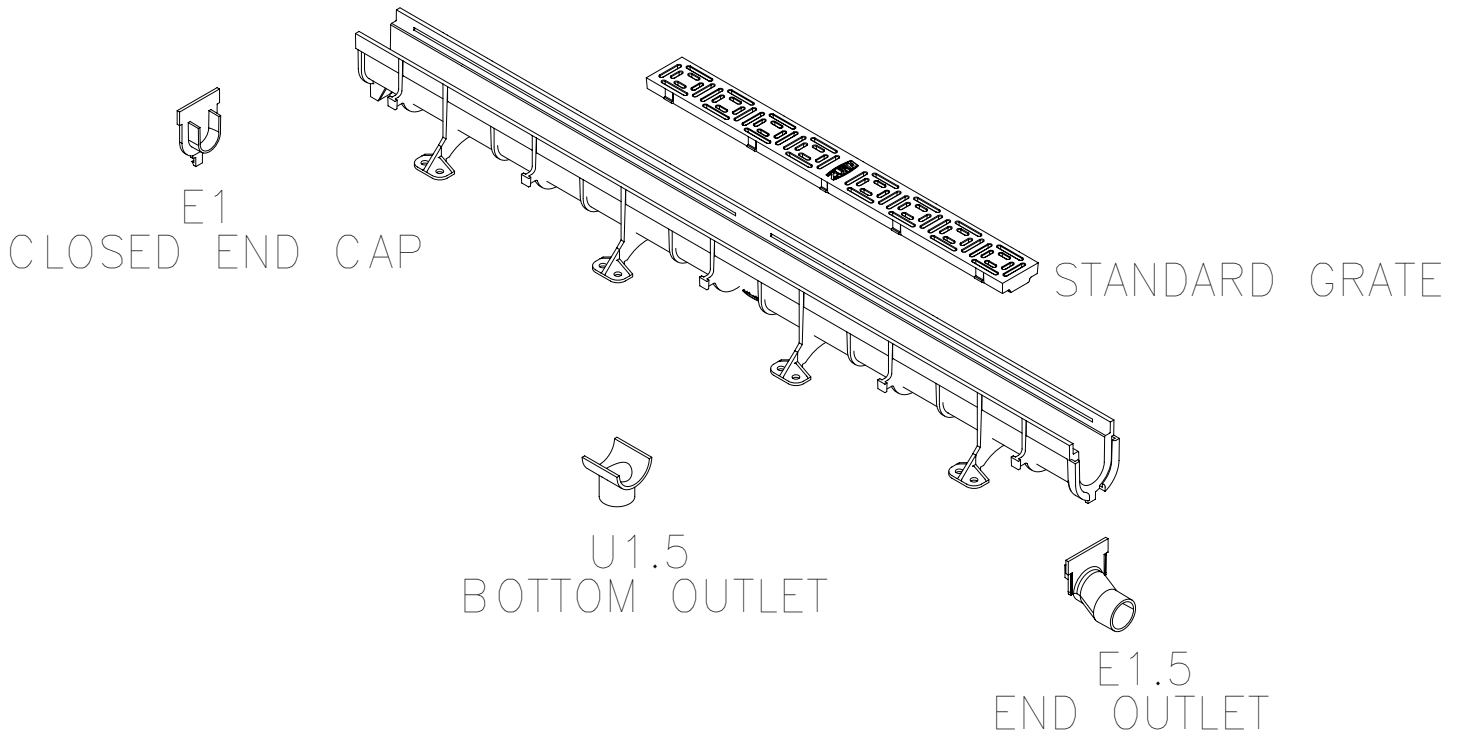

Above are some of the trench drain components typical to an installation. Double check your order to ensure that you have all components particular to your job before beginning your installation.

Contact Zurn 'Flo-Thru' at 855-663-9876 should material be required.

- ⚠ **WARNING:** Cancer and Reproductive Harm - www.P65Warnings.ca.gov
- ⚠ **ADVERTENCIA:** Cáncer y daño reproductivo - www.P65Warnings.ca.gov
- ⚠ **AVERTISSEMENT:** Cancer et effets néfastes sur la reproduction - www.P65Warnings.ca.gov

Zurn Industries, LLC | Specification Drainage Operation
1801 Pittsburgh Avenue, Erie, PA 16502, Ph. 855.663.9876

In Canada | Zurn Industries Limited
7900 Goreway Drive, Unit 10, Brampton, Ontario L6T 5W6, Ph. 877.892.5216

www.zurn.com

Rev. B
Date: 04/21/2022
C.N. No. 144452
Form No. FT902



Z880
EXCAVATION

Design and Dimensional Data (inches and [mm]) are Subject to Manufacturing Tolerances and Change Without Notice

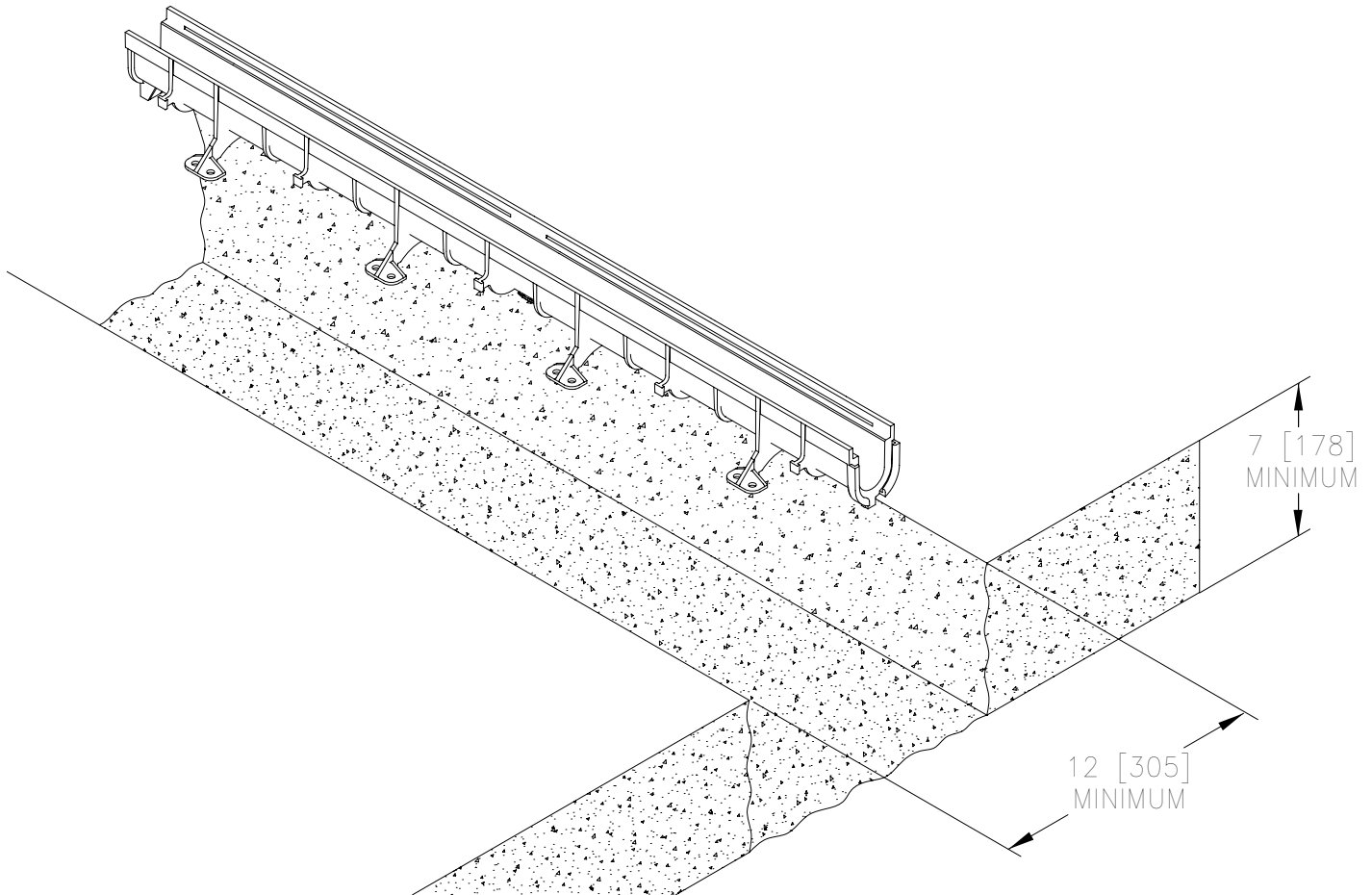

Trench excavation must be 4" [102mm] greater than the trench depth and a minimum of 4" [102mm] greater than the edge of the trench on each side. Soft and/or shifting soil substrates may cause cracking of the concrete and consequent movement of the trench. It is critical that the concrete be poured on an adequate foundation.

- ⚠ **WARNING:** Cancer and Reproductive Harm - www.P65Warnings.ca.gov
- ⚠ **ADVERTENCIA:** Cáncer y daño reproductivo - www.P65Warnings.ca.gov
- ⚠ **AVERTISSEMENT:** Cancer et effets néfastes sur la reproduction - www.P65Warnings.ca.gov

Zurn Industries, LLC | Specification Drainage Operation
1801 Pittsburgh Avenue, Erie, PA 16502, Ph. 855.663.9876

In Canada | Zurn Industries Limited
7900 Goreway Drive, Unit 10, Brampton, Ontario L6T 5W6, Ph. 877.892.5216

www.zurn.com

Rev.	B
Date:	04/21/2022
C.N. No.	144452
Form No.	FT902



Z880 JOINT CONNECTION

Design and Dimensional Data (inches and [mm]) are Subject to Manufacturing Tolerances and Change Without Notice

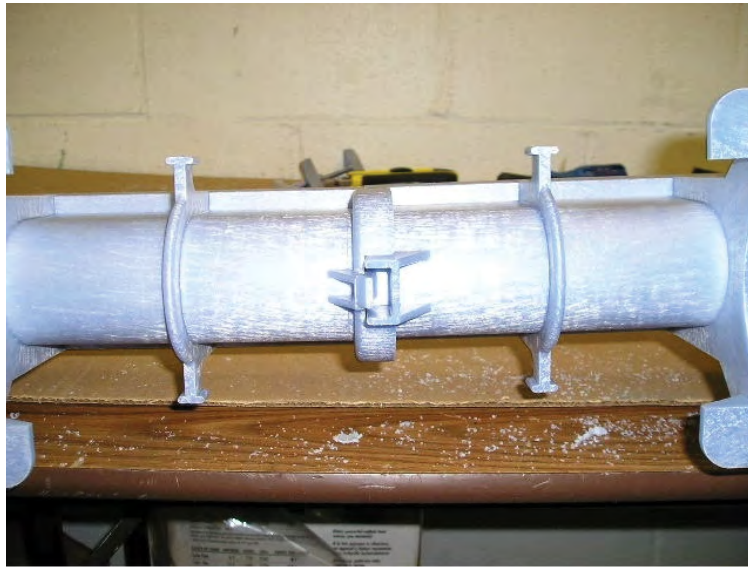
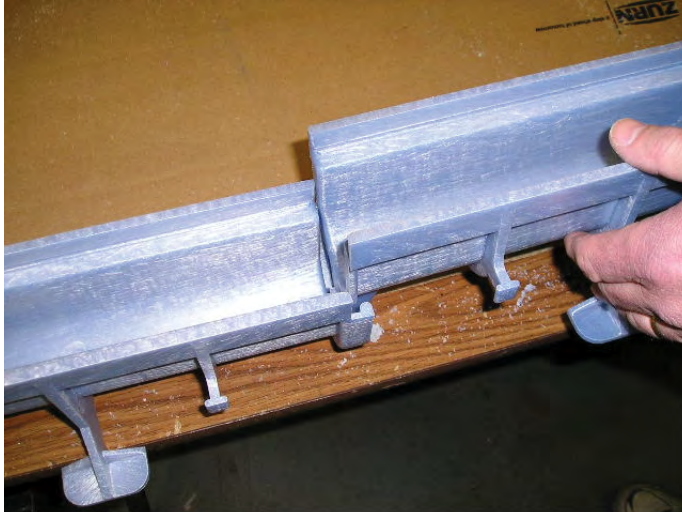

Assembling the trench run is easy using 'Flo-Thru's' mechanical interlocking joints. Simply align the male end above the female end and slide together. The bottom interlock should snap together. A silicone caulk, or a construction adhesive, such as Liquid Nails, is recommended to be used at each joint as a sealer.

- ⚠ **WARNING:** Cancer and Reproductive Harm - www.P65Warnings.ca.gov
- ⚠ **ADVERTENCIA:** Cáncer y daño reproductivo - www.P65Warnings.ca.gov
- ⚠ **AVERTISSEMENT:** Cancer et effets néfastes sur la reproduction - www.P65Warnings.ca.gov

Zurn Industries, LLC | Specification Drainage Operation
1801 Pittsburgh Avenue, Erie, PA 16502, Ph. 855.663.9876

In Canada | Zurn Industries Limited
7900 Goreway Drive, Unit 10, Brampton, Ontario L6T 5W6, Ph. 877.892.5216

www.zurn.com

Rev.	B
Date:	04/21/2022
C.N. No.	144452
Form No.	FT902



Z880

OUTLETS AND ACCESSORIES

Design and Dimensional Data (inches and [mm]) are Subject to Manufacturing Tolerances and Change Without Notice

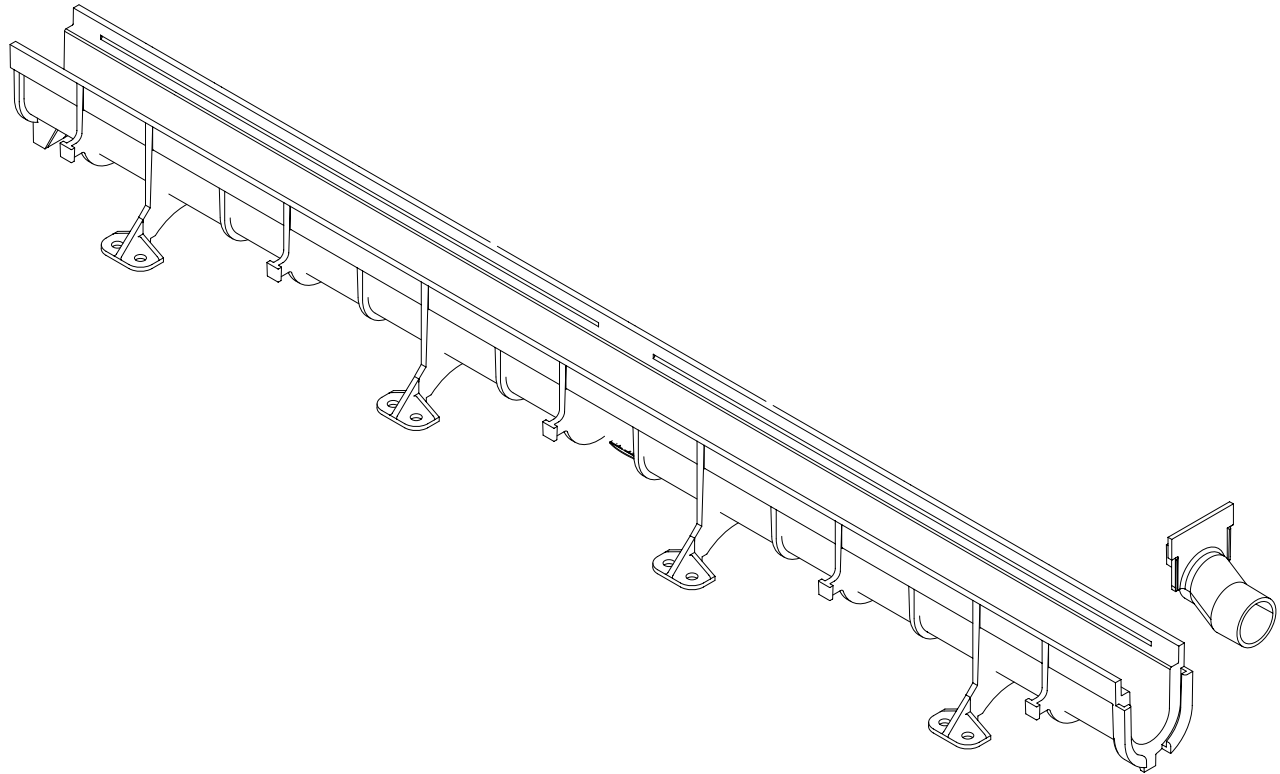

A bottom outlet is attached to the bottom side of the trench drain with provided screws and a silicone caulk or a construction adhesive if desired as shown below. It may be necessary to remove a underside rib to allow the outlet to sit flat. A hole saw can be used to cut the appropriate size hole through the bottom of the trench.

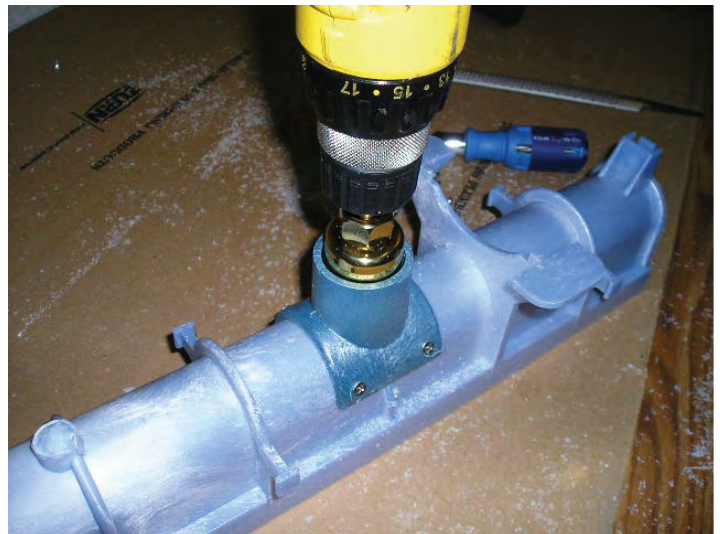

⚠ WARNING: Cancer and Reproductive Harm - www.P65Warnings.ca.gov

⚠ ADVERTENCIA: Cáncer y daño reproductivo - www.P65Warnings.ca.gov

⚠ AVERTISSEMENT: Cancer et effets néfastes sur la reproduction - www.P65Warnings.ca.gov

Zurn Industries, LLC | Specification Drainage Operation
1801 Pittsburgh Avenue, Erie, PA 16502, Ph. 855.663.9876

In Canada | Zurn Industries Limited
7900 Goreway Drive, Unit 10, Brampton, Ontario L6T 5W6, Ph. 877.892.5216

www.zurn.com

Rev. B
Date: 04/21/2022
C.N. No. 144452
Form No. FT902



Z880 OVERALL LAYOUT

Design and Dimensional Data (inches and [mm]) are Subject to Manufacturing Tolerances and Change Without Notice

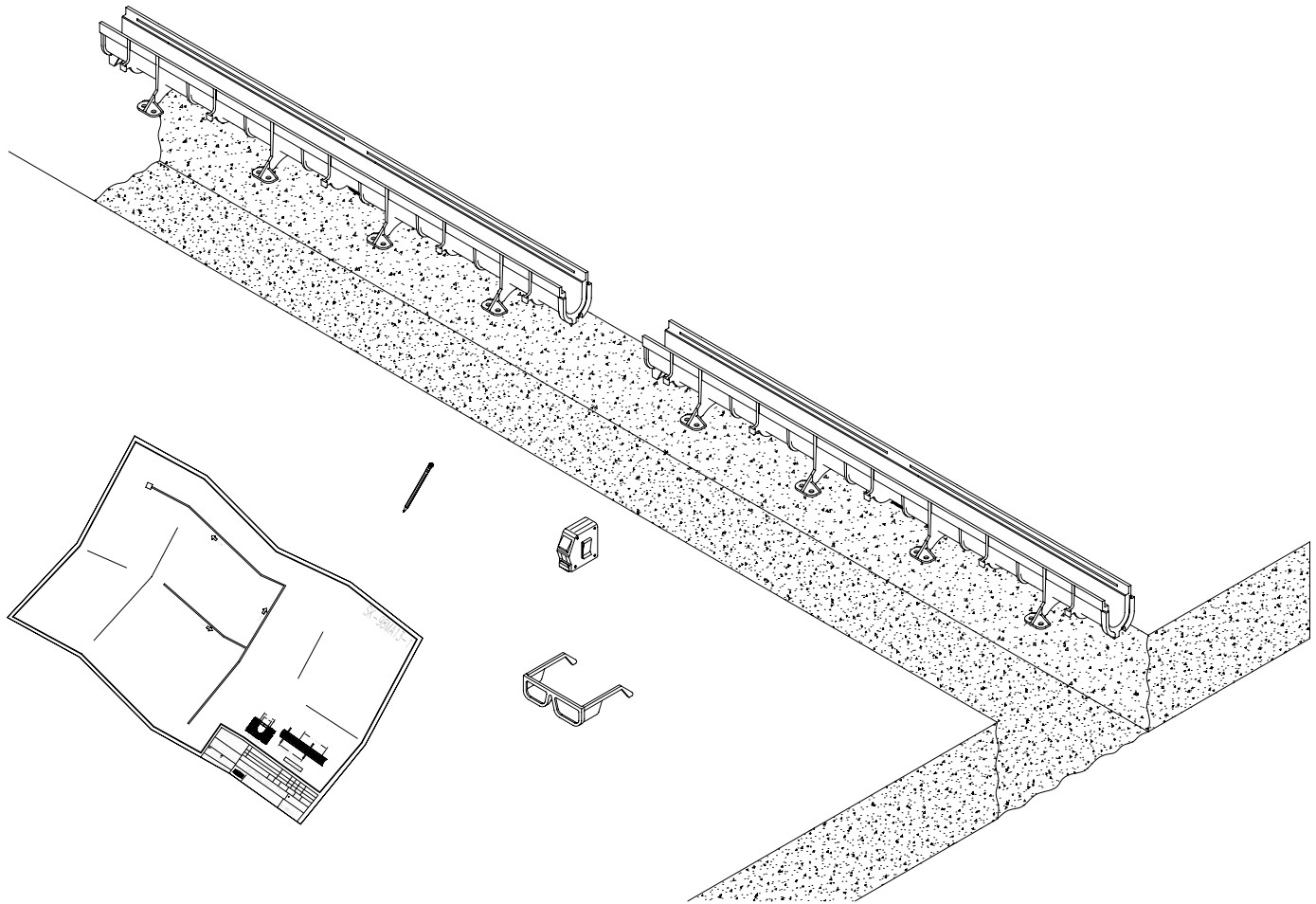

Upon completion of the trench excavation, the channels should be placed in order alongside the excavation and according to the job layout.

⚠ WARNING: Cancer and Reproductive Harm - www.P65Warnings.ca.gov

⚠ ADVERTENCIA: Cáncer y daño reproductivo - www.P65Warnings.ca.gov

⚠ AVERTISSEMENT: Cancer et effets néfastes sur la reproduction - www.P65Warnings.ca.gov

Zurn Industries, LLC | Specification Drainage Operation
1801 Pittsburgh Avenue, Erie, PA 16502, Ph. 855.663.9876

In Canada | Zurn Industries Limited
7900 Goreway Drive, Unit 10, Brampton, Ontario L6T 5W6, Ph. 877.892.5216

www.zurn.com

Rev. B
Date: 04/21/2022
C.N. No. 144452
Form No. FT902



Z880

SETTING THE TRENCH

Design and Dimensional Data (inches and [mm]) are Subject to Manufacturing Tolerances and Change Without Notice

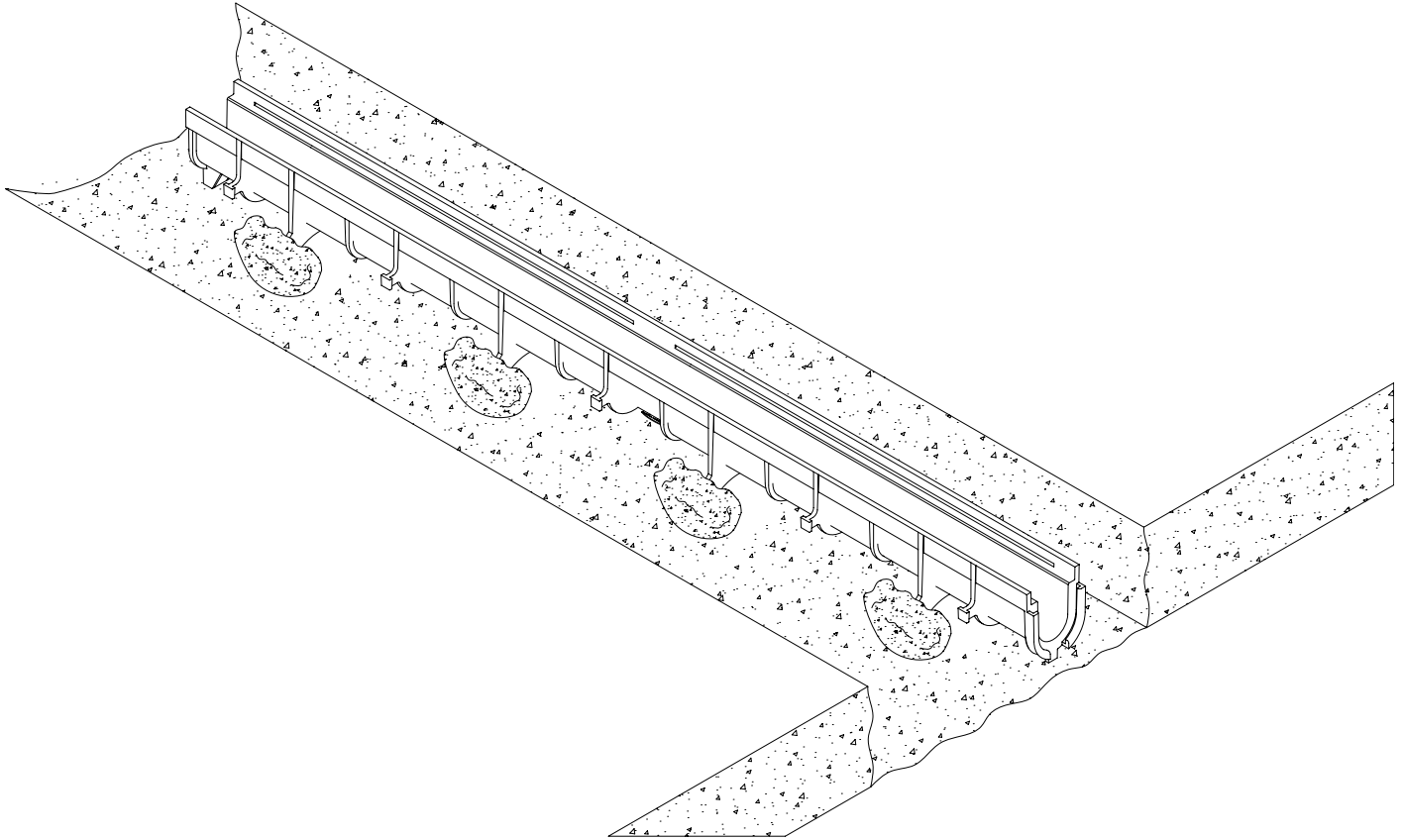

* It is recommended to pour concrete the same day the trench is set. Failure to do so could cause trench cracking when subjected to temperature variations.

After attachment of accessories, anchor and level trench in the excavation using concrete patties around the feet. Make finish pour of concrete and be certain to properly vibrate concrete to eliminate any unwanted voids. Finish troweling should be done to set the top edge of the trench drain 1/16" [1.6mm] below the floor grade. Remember to compensate for concrete shrinkage that may occur during cure so that the edge of the trench drain does not protrude above the finished floor grade.

- ⚠ **WARNING:** Cancer and Reproductive Harm - www.P65Warnings.ca.gov
- ⚠ **ADVERTENCIA:** Cáncer y daño reproductivo - www.P65Warnings.ca.gov
- ⚠ **AVERTISSEMENT:** Cancer et effets néfastes sur la reproduction - www.P65Warnings.ca.gov

Zurn Industries, LLC | Specification Drainage Operation
1801 Pittsburgh Avenue, Erie, PA 16502, Ph. 855.663.9876

In Canada | Zurn Industries Limited
7900 Goreway Drive, Unit 10, Brampton, Ontario L6T 5W6, Ph. 877.892.5216

www.zurn.com

Rev. B
Date: 04/21/2022
C.N. No. 144452
Form No. FT902