

Model ZW3870XLT

LEAD-FREE*



Aqua-Gard® Thermostatic Mixing Valve

*This product contains a weighted average lead content less than 0.25% for wetted surfaces.

□ Installation □ Maintenance Instructions

INSTALLATION INSTRUCTIONS

It is suggested that the device be installed to deliver water to the end user. It is to be used for the final control of water temperature at plumbing fixtures and appliances. This ASSE 1070 approved device is to be used for point of use. It is designed to mix cold water and hot water from the water heater to a safer temperature range of 95-115°F (35-46°C).

1. Flush the Hot and Cold delivery lines completely before installing the device.
2. The device can be installed in any position. Note: the inlet hot supply is to be connected to the "H" side of the valve and the cold supply side to the "C" side.
3. The valve is to be fitted to deliver mixed water to a single outlet.
4. To set the temperature on the valve remove the protective blue cap. The cap can be removed by inserting a small blade screwdriver into the slot at the base of the blue cap and lightly push up. Using an adjustable wrench or combination wrench, rotate the flats clockwise to lower the temperature or counter-clockwise to increase the set temperature. Read temperature with a thermometer.
5. Verify the set temperature by running a plumbing fixture and reinstall the protective plastic cap to the device. For bathroom operation set the maximum temperature not to exceed 95-115°F (35-46°C)

PERFORMANCE

Outlet Temp. Range	95-115°F(35-46°C)
Temperature Hot Supply	120-195°F max. (49-90.5°C)
Temperature Cold Supply	40-75°F (4.4-23.8°C)
Set Temperature Accuracy	+/- 3°F(1.78°C)
Max. Working Pressure (inlet)	145 psi
Temperature must be field set	
Max. Working Pressure (Dynamic)	1.5-70 psi
Flow rate @ 45 psi pressure loss	3.10 gpm
Min. Flow Rate	0.35 gpm

DIMENSIONS

SIZE		MODEL	DIMENSIONS (approximate)												WEIGHT	
			A		B		C		D		E		F			
in.	mm		in.	mm	in.	mm	in.	mm	in.	mm	in.	mm	in.	mm	lbs.	kg.
3/8	9.5	ZW3870XLT	4 13/16	122.2	4 17/32	115	6	152	1	25.4	3	76.2	2 5/8	66.7	1.5	.68

*With supplied check valves. Note: check valves must be used for proper operation.

WARRANTY: ZURN WILKINS Valves are guaranteed against defects of material or workmanship when used for the services recommended. If in any recommended service, a defect develops due to material or workmanship, and the device is returned, freight prepaid, to ZURN WILKINS within 12 months from date of purchase, it will be repaired or replaced free of charge. ZURN WILKINS' liability shall be limited to our agreement to repair or replace the valve only.

Proposition 65 Warning This product contains chemicals known to the State of California to cause cancer or birth defects or other reproductive harm.

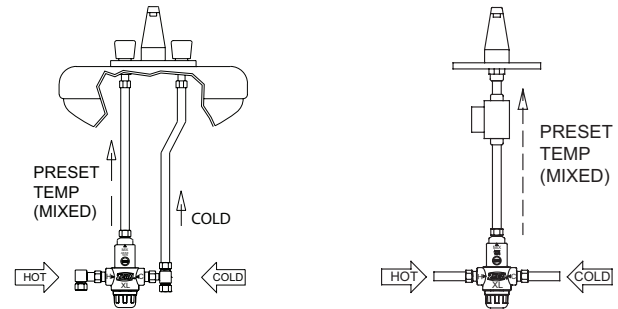

INDIVIDUAL USE

SINGLE USE

PIPING INSTRUCTIONS

The device is designed to be installed at a single outlet. It may be used to supply individual outlets when there is sufficient supply pressure. It is suggested to use ball valves on the Hot and Cold inlet supplies.

CAUTION: Installation of water temperature control products must be performed by qualified, licensed personnel. The qualified installer should be sure that the proper device has been selected for the proper installation. A faulty installation can cause scalding, severe injury or death.

NOTICE: Annual inspection and maintenance is required of all plumbing system components. To ensure proper performance and maximum life, this product must be subject to regular inspection, testing and cleaning.

WARNING! Water Temperatures in Excess of 122°F(50°C) Are Dangerous and Will Cause Scalding, Severe Injury or Death! This valve is Not Factory preset. To deliver a safe mixed water temperature at the outlet, the installer must use a thermometer at the outlet to verify the temperature. Set the outlet temperature between 95°F and 115°F

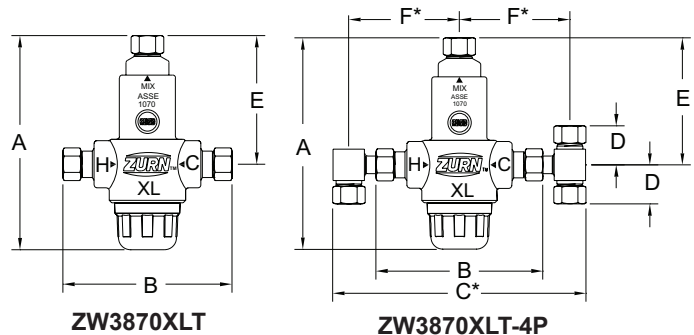

ZW3870XLT

ZW3870XLT-4P

MATERIALS

Body	Low Lead Bronze, nickel plated
Internal brass	Low Lead Brass
Piston	Polysufone
Guide Tube	Noryl GFN2
Spring	300 Series Stainless Steel
Seals	Nitrile Elastomer
Checks	Delrin

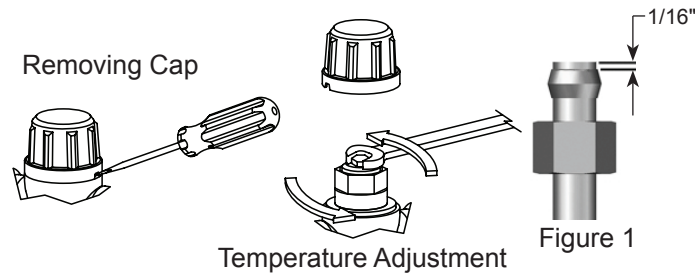

COMPRESSION FITTING INSTALLATION

It is recommended that the end of the inlet supply tube, tee fitting or 90 degree elbow extend 1/16" beyond the ferrule for adequate compression as illustrated above in Figure 1.

MAINTENANCE

SERVICING THE CHECK VALVES

The check valves can be serviced by removing them from the body, flushing the check valves thoroughly with water removing debris from the seat and seat washers. Reinstall the check valve by pushing them into the body flush with the body, spring first. Make sure that the pop-pet and seat washer are facing you.

OPERATION

The valve internals themselves cannot be serviced. If the valve fails it must be replaced. The function of the valve can be checked by measuring the temperature of the water at the outlet nearest to the valve. If the temperature is within $\pm 3^{\circ}\text{F}$ of the initial set temperature, the valve is functioning correctly. If the temperature has changed by more than $\pm 4^{\circ}\text{F}$ it is likely due to a build up of debris in the strainers or a change in the supply condition.

FLOW CHARACTERISTIC

MODEL ZW3870XLT, ZW3870XLT-4P

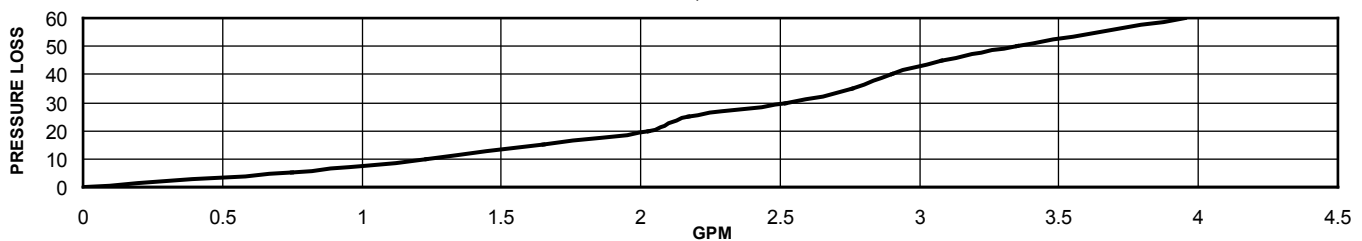

TROUBLESHOOTING

Problem	Cause	Solution
The desired mixed water temp. cannot be obtained or valve is difficult to set	Hot and Cold supplies are reversed, valve is full of debris.	Refit valve so H & C are correct, flush valve with water
Mix Temperature is unstable	Fluctuating supply pressure	Install PRV's on H & C inlet supplies
Mix Temperature changing over time	Fluctuating supply pressures	Install PRV's
Either full Hot or Cold water flowing	Valve is set incorrectly	Adjust mix. Temperature to 95-115°F
No flow from the valve outlet	Hot or Cold water supply failure	Restore inlet supply & check mix. Temperature
Flow rate reduced or fluctuating	Valve or inlet fitting fouled by debris	Check valve and inlet fittings for block-age
Mixed water temp. too Hot or Cold	Valve has been tampered with, valve incorrectly set, or inlet temperatures are not within specified limits	Re-adjust to required set temp. to ensure inlet temperatures are within specified limits
Mixed water temp. does not change when the temp. adjuster is moved	Hot and Cold supplies are reversed	Refit the valve to correct Hot and Cold
Hot water flows into the cold water system or vice versa	Check valve is fouled	Remove debris
Valve is noisy	Water velocity is too high	Reduce water velocity
Little or no flow from valve outlet	Inlet supply tube extending more than 1/16" beyond ferrule	Shorten tube then remove and replace inlet check valves
Little or no flow from valve outlet	Inlet screens plugged with debris	Clean inlet screens