

Model 450 & 450DA

Double Check Valve Assembly (8" & 10")

Double Check Detector Assembly (8" & 10")

WILKINS

a ZURN company

(Patent No. 5,913,331)

□ Installation □ Testing □ Maintenance Instructions

INSTALLATION INSTRUCTIONS

CAUTION: Installation of Backflow Preventers must be performed by qualified, licensed personnel. The installer should be sure the proper device has been selected for the particular installation. Faulty installation could result in an improperly functioning device.

WILKINS Model 450 Double Check Valve Assemblies are for use on potable water lines where a health hazard does not exist in the event of a backflow situation.

Damage to the device could result wherever water hammer and/or water thermal expansion could create excessive line pressure. Where this could occur, shock arrestors, check valves and/or pressure relief valves should be installed downstream of the device.

If installation is in a pit or vault, the Backflow Preventer must never be submerged in water because this could cause a cross-connection. Make sure that the pit or vault always remains dry by providing ample drainage.

1. Before installing a Model 450 Backflow Preventer, flush the line thoroughly to remove all debris, chips and other foreign matter. If required, a strainer should be placed upstream of the Backflow Preventer. **CAUTION:** Do not use a strainer in seldom used emergency waterlines such as fire lines.
2. Provide adequate space around the installed unit so that the test cocks will be accessible for testing and servicing.
3. Install valve at least 12 inches above surrounding flood level.
4. Always consult local codes for installation methods, approvals and guidance.

OUTDOOR INSTALLATION

The Model 450 Backflow Preventer may be installed outdoors only if the device is protected against freezing conditions. Exposure to freezing conditions will result in improper function or damage to the device. The installation location must be kept above 32°F. All the basic installation instructions apply.

INDOOR INSTALLATION

Indoor installation is preferred in areas that are subject to freezing conditions. All the basic installation instructions apply to such installations.

PLACING THE DEVICE IN SERVICE

1. Start with both shut-off valves closed. Slowly open the inlet shut-off valve until the backflow preventer is completely pressurized.
2. When the unit has been pressurized, vent any trapped air by slightly opening each of the four test cocks.
3. Slowly open the downstream shut-off valve. The Model 450 Double Check Valve assembly is now in service.
4. After the Model 450 has been properly installed, test the device (see "TEST PROCEDURES"). If the device fails the test, remove the first and second check valves and thoroughly flush the device. Clean rubber and seats of all debris and place unit back in service.

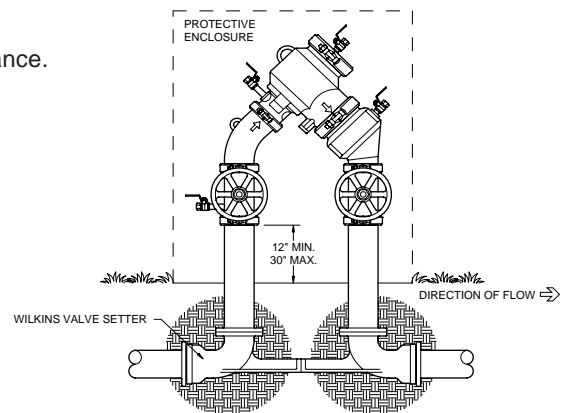

TYPICAL HORIZONTAL ORIENTATION

Proposition 65 Warning This product contains chemicals known to the State of California to cause cancer or birth defects or other reproductive harm.

Testing Procedures

MODEL 450 DOUBLE CHECK VALVE ASSEMBLY

Equipment Required: Differential pressure gauge test kit.

TEST NO. 1 - TIGHTNESS OF #1 CHECK VALVE

REQUIREMENT:

The static pressure drop across check valve #1 shall be at least 1.0 psid. If test cock #3 is not at the highest point of the check valve body, then a vertical tube must be installed on test cock #3 so that it rises to the top of the check valve body.

PROCEDURE:

1. Slowly open all 4 test cocks to remove any foreign material and attach fittings.
2. Attach hose from the high side of the test kit to the #2 test cock.
3. Open test cock #2 and bleed all air from the hose and gauge by opening the high side bleed needle valve. Close high side bleed needle valve. If a tube is attached to test cock #3, open test cock #3 to fill the tube. Close test cock #3. Close #2 shut-off valve then close the #1 shut-off valve.
4. Hold gauge at same level as test cock #3 or water level in tube. Slowly open test cock #3. Record the static pressure drop across check valve #1 after gauge reading stabilizes and water stops running out of test cock #3.
5. Close all test cocks, open shut-off valve #1 and remove test equipment.

TEST NO. 2 - TIGHTNESS OF #2 CHECK VALVE

REQUIREMENT:

The static pressure drop across check valve #2 shall be at least 1.0 psid. If test cock #4 is not at the highest point of the check valve body, then a vertical tube must be installed on test cock #4 so that it rises to the top of the check valve body.

PROCEDURE:

1. Attach hose from the high side of the test kit to the #3 test cock.
2. Open test cock #3 and bleed all air from the hose and gauge by opening the high side bleed needle valve. Close high side bleed needle valve. If a tube is attached to test cock #4, open test cock #4 to fill the tube. Close test cock #4. Close #1 shut-off valve.
3. Hold gauge at same level as test cock #4 or water level in tube. Slowly open test cock #4. Record the static pressure drop across check valve #2 after gauge reading stabilizes and water stops running out of test cock #4.
4. Close all test cocks, slowly open shut-off valve #1 & #2 and remove test equipment.

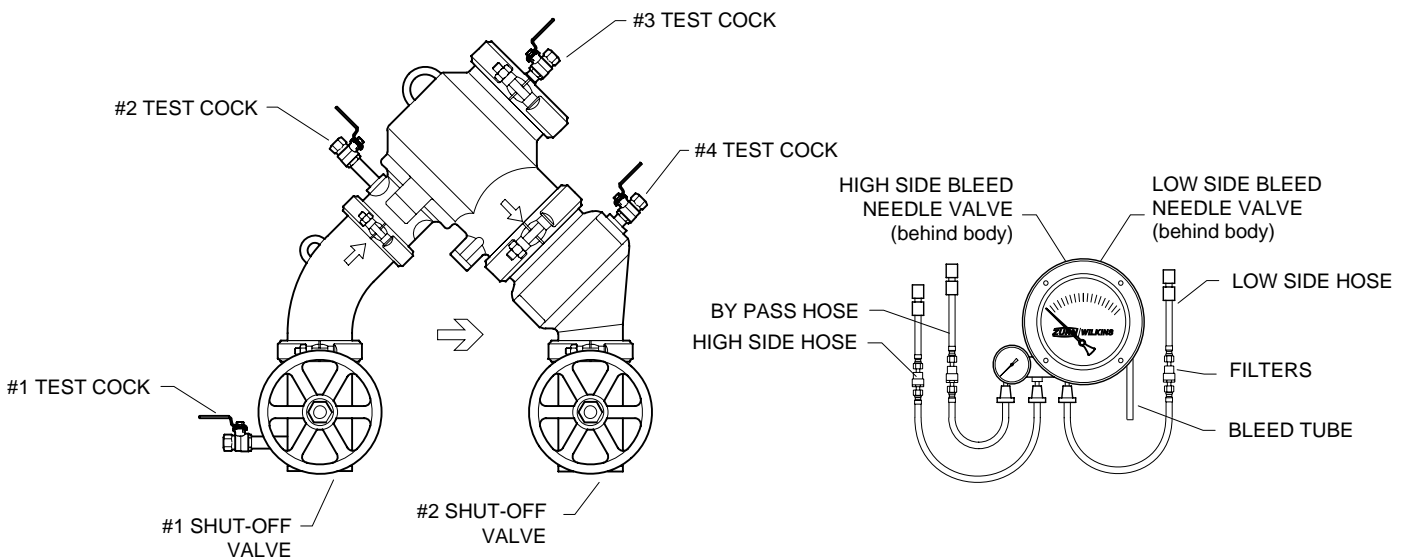

Maintenance Instructions

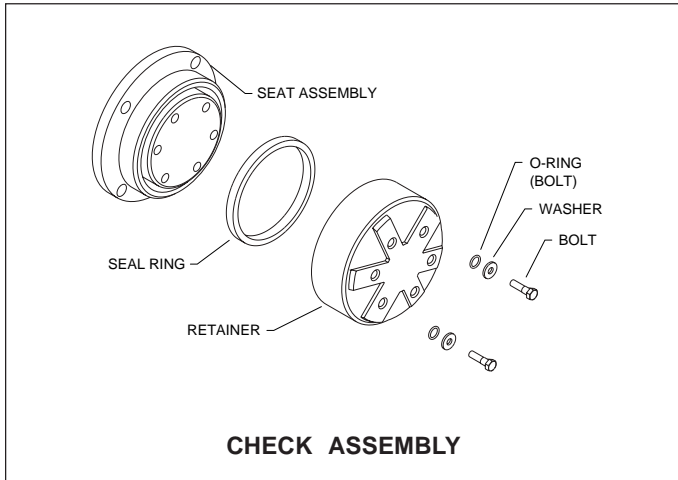

All Model 450 Double Check Valve Backflow Preventers must be inspected and maintained by licensed personnel at least once a year or more frequently as specified by local codes. Replacement of worn or damaged parts must only be made with genuine "WILKINS" parts.

GENERAL MAINTENANCE

1. Clean all parts thoroughly with water after disassembly.
2. Carefully inspect rubber seal rings and o-rings for damage.
3. Test unit after reassembly for proper operation (refer to "TESTING PROCEDURES").

SERVICING CHECK VALVES

1. Close inlet and outlet shut-off valves.
2. Open No. 2, No. 3 and No. 4 test cocks to release pressure from valve.
3. Loosen & remove the grooved coupling around the access cover. Remove cover.
4. To service only the #1 check assembly, remove the 6 bolts, washers and o-rings from the back of the #1 check assembly. Separate the retainer and the seal ring from the check assembly and proceed to step #8.
5. To service both checks or the #2 check, the #1 check assembly must first be removed. Remove the 4 nuts and washers retaining the #1 check assembly. Remove the #1 check assembly from the body.
6. To remove the #2 check assembly, remove the 7 nuts, washers and the #2 check retaining ring. Grasp the check assembly by the stem and remove from valve.
7. Remove all 6 bolts, washers and o-rings from the check assembly (See "Check Assembly" illustration). Separate retainer from check assembly to expose seal ring for inspection.
8. Inspect the rubber seal ring for cuts or embedded debris. If the reverse side of the seal ring is unused, it is possible to invert the seal ring. This would be considered a temporary solution to fixing a fouled check and should be replaced with a new seal ring as soon as possible.
9. Inspect valve cavity and seating areas. Remove any debris.
10. Reverse the above procedures to reinstall check assemblies. Lubricate seat o-rings to hold them in place while reinstalling seat. Place washers on studs and tighten retaining nuts evenly.
11. Reinstall access cover and grooved coupling.

NOTE: If any portion of the seat assembly is damaged or missing or if the seat sealing rib is damaged in any way, do not attempt to field repair it. Contact your local WILKINS representative for assistance.

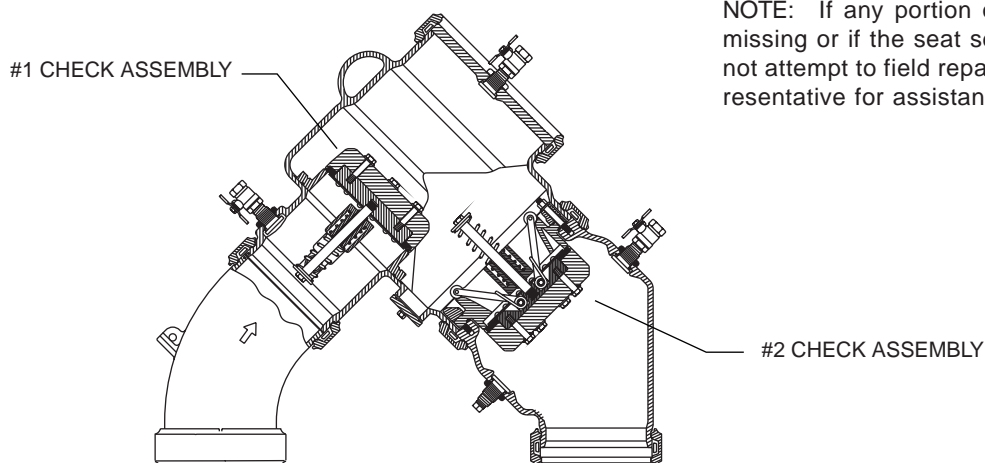

Troubleshooting

PROBLEM	POSSIBLE CAUSES	CORRECTIVE ACTION
1. LEAKING CHECK VALVES	1. Debris on seat or seal ring 2. Damaged seat area 3. Damaged seat o-ring 4. Damaged bolt o-ring(s) on check retainer	1. Clean seat area 2. Replace check assembly 3. Replace seat o-ring 4. Replace o-ring(s)
2. LOW OR NO FLOW	1. Device installed backwards 2. Gate valves not fully open 3. Low supply pressure	1. Verify flow direction arrow 2. Turn handles counterclockwise 3. Attach pressure gauge to test cock #1 and verify pressure

Repair Kits

SIZE: 8" & 10"
 MODEL 450 CHECKS ONLY: RK8-350

Performance Characteristics

MODEL 450 6", 8" & 10" (STANDARD & METRIC)

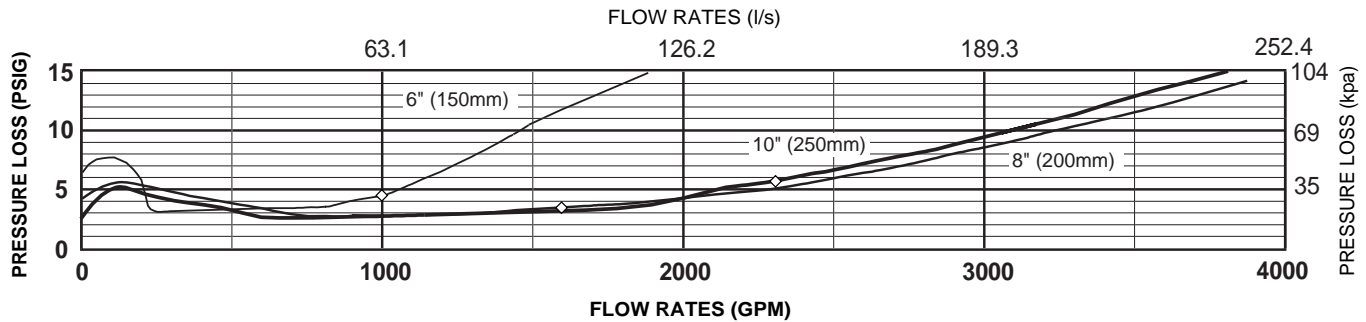

MODEL 450DA 6", 8" & 10" (STANDARD & METRIC)

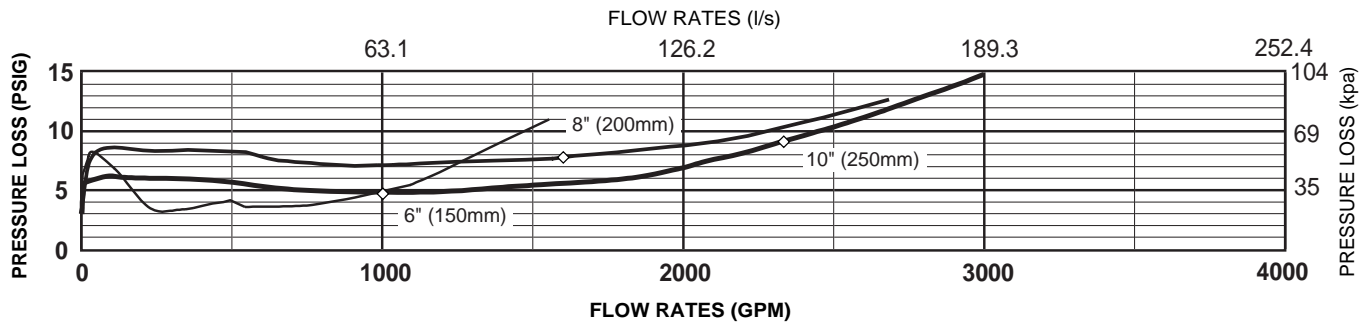

◇ Rated Flow (Established by approval agencies)

Capacity thru Schedule 40 Pipe (GPM)				
Pipe size	5 ft/sec	7.5 ft/sec	10 ft/sec	15 ft/sec
2 1/2"	75	112	149	224
3"	115	173	230	346
4"	198	298	397	595
6"	450	675	900	1351
8"	780	1169	1559	2339
10"	1229	1843	2458	3687

SPECIFICATIONS

Maximum working water pressure: 175 PSI
 Maximum working water temperature: 140°F
 Hydrostatic test pressure: 350 PSI
 End connections: Flanged ANSI B16.1 Class 125

Proper performance is dependent upon licensed, qualified personnel performing regular, periodic testing according to WILKINS' specifications and prevailing governmental & industry standards and codes and upon following these installation instructions. Failure to do so releases WILKINS of any liability that it might otherwise have with respect to that device. Such failure could also result in an improperly functioning device.

WILKINS
 a ZURN company