

SPECIFICATION SUBMITTAL SHEET

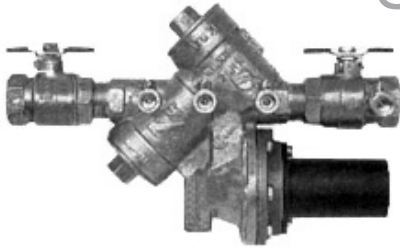

FEATURES

Sizes: 3/4" 1" 1 1/4" 1 1/2" 2"

Maximum working water pressure 175 PSI
 Maximum working water temperature 180°F
 Hydrostatic test pressure 350 PSI
 End connections Threaded ANSI B1.20.1

UL® recognized switch factory installed, tested and ready for immediate installation

OPTIONS

(Suffixes can be combined)

- with full port QT ball valves (standard)
- L - less ball valves
- U - with union ball valves
- S - with bronze "Y" type strainer

ACCESSORIES

- Air gap (Model AG)
- Repair kit (rubber only)
- Thermal expansion tank (Model WXTP)
- Soft seated check valve (Model 40)
- Shock arrester (Model 1250)
- QT-SET Quick Test Fitting Set
- Test Cock Lock (Model TCL24)

Relief Valve discharge port:
 3/4" - 1" - 0.63 sq. in.
 1 1/4" - 2" - 1.19 sq. in.

APPLICATION

Designed for installation on potable water lines to protect against both backsiphonage and backpressure of contaminated water into the potable water supply. Assembly shall provide protection where a potential health hazard exists. The 975XLBMS is ideal for use in mechanical rooms, basements and enclosures where undetected relief valve discharge could potentially cause water damage. It is equipped with a phone jack for alarm output to an on-site alarm system, a remote alarm company, or a auto dialer.

STANDARDS COMPLIANCE

- ASSE® Listed 1013
- IAPMO® Listed
- AWWA Compliant C511
- CSA® Certified
- Approved by the Foundation for Cross-Connection Control and Hydraulic Research at the University of Southern California
- NYC MEA 425-89-M VOL 3

MATERIALS

Main valve body	Cast Bronze ASTM B 584
Access covers	Cast Bronze ASTM B 584
Internals	Stainless Steel, 300 Series
Elastomers	Silicone (FDA approved) Buna Nitrile (FDA approved)
Polymers	Noryl™, NSF Listed
Springs	Stainless steel, 300 series
Switch cover	ABS; UV resistant

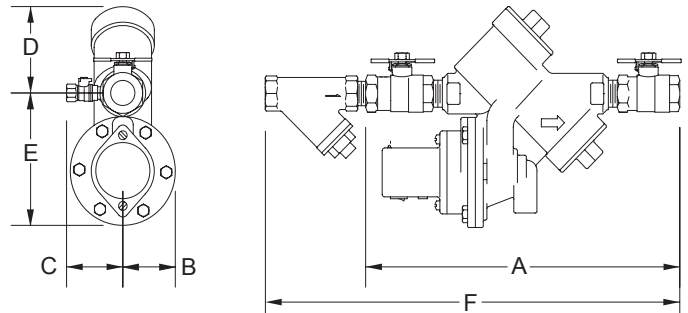

DIMENSIONS & WEIGHTS (do not include pkg.)

MODEL SIZE	DIMENSIONS (approximate)																WEIGHT				
	A		A UNION BALL VALVES		A LESS BALL VALVES		B		C		D		E		F		LESS BALL VALVES		WITH BALL VALVES		
	in.	mm	in.	mm	in.	mm	in.	mm	in.	mm	in.	mm	in.	mm	in.	mm	lbs	kg	lbs.	kg	
3/4	20	12	305	13 3/4	349	7 3/4	197	2 1/8	54	3	76	3 1/2	89	5	127	16 1/8	410	10	4.5	12	5.5
1	25	13	330	14 1/2	368	7 3/4	197	2 1/8	54	3	76	3 1/2	89	5	127	17 3/8	441	11	5	15	6.8
1 1/4	32	17	432	18 13/16	478	10 15/16	278	2 3/4	70	3 1/2	89	5	127	6 3/4	171	22 9/16	573	22	10	28	12.7
1 1/2	40	17 3/8	441	19 3/8	492	10 15/16	278	2 3/4	70	3 1/2	89	5	127	6 3/4	171	24 1/16	611	22	10	28	12.7
2	50	18 1/2	470	20 1/2	521	10 15/16	278	2 3/4	70	3 1/2	89	5	127	6 3/4	171	26 1/2	673	22	10	34	15.4

FLOW CHARACTERISTICS

MODEL 975XLMS/975XLBMS 3/4", 1", 1 1/4", 1 1/2" & 2" (STANDARD & METRIC)

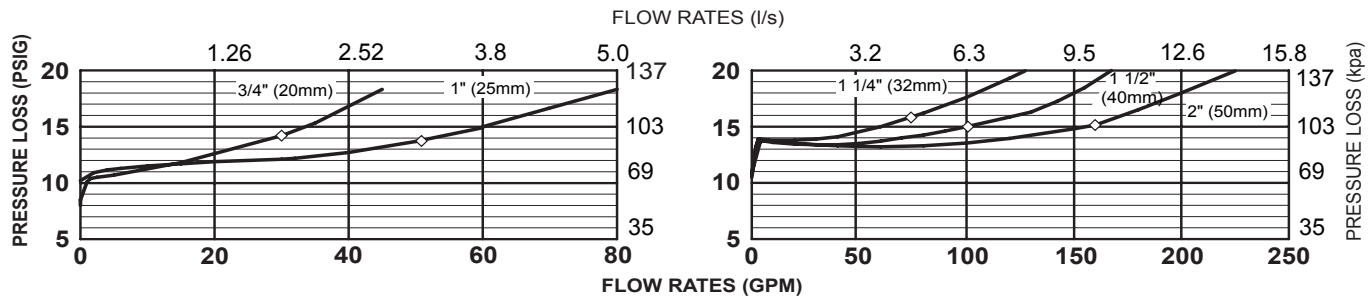

◇ Rated Flow (Established by approval agencies)

Relief Valve Discharge Rate @ BMS Alarm Signal (Factory Set)	
Pipe size	Inlet Pressure
	50 psi
3/4"-1"	5 gpm
1 1/4"-2"	10 gpm

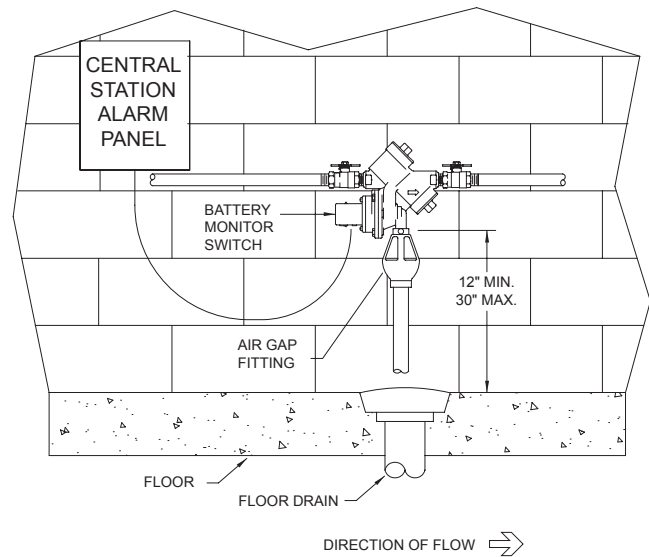

TYPICAL INSTALLATION

TYPICAL INSTALLATION

Local codes shall govern installation requirements. To be installed in accordance with the manufacturers' instructions and the latest edition of the Uniform Plumbing Code. Unless otherwise specified, the assembly shall be mounted at a minimum of 12" (305mm) and a maximum of 30" (762mm) above adequate drains with sufficient side clearance for testing and maintenance. Note: If installed outdoors, a protective enclosure is recommended. The installation shall be made so that no part of the unit can be submerged.

SWITCH OPERATION

Once the assembly is installed and the system pressurized, the switch (BMS) can be turned on. In the event of a backflow condition, the relief valve closes an electrical contact and a high pitched alarm begins sounding, signaling that a relief valve discharge is occurring. To prevent false alarms due to intermittent line pressure fluctuations, the BMS is equipped with a 10-second delay. An LED blinks every 40 seconds as long as the battery is sufficiently charged to power the BMS. Remote alarm hook-up via phone jack (RJ11) internal 1 amp/125 volt switch closure and user-supplied external wiring and alarm panel connection. It is recommended that the battery be replaced during the annual backflow field test. Contact factory for alarm options and details.

SPECIFICATIONS

The Reduced Pressure Principle Assembly shall be rated to 180°F and supplied with full port ball valves and integral battery operated monitor switch. The checks shall be accessible for maintenance without removing the valve from the line. The monitor switch shall be easily deactivated for maintenance of the entire assembly and the battery shall be accessible for replacement. If installed indoors, the installation shall be supplied with an air gap adapter and piped to a properly sized drain. The Reduced Pressure Principle Assembly shall be a WILKINS Model 975XLBMS.