

Model FP23, FP23R, FP23F

Couplings

(1", 1 1/4", 1 1/2", 2", 2 1/2", 3", 4", 6", 8", 10")



□ Installation Instructions

Application

Zurn Model FP23 couplings are listed to join grooved pipes together. FP23 couplings are available with Rigid or Flexible options, or for reducing connections.

Safety Warning:

Read and understand all instructions before attempting to install any piping products. Depressurize and drain the piping system before attempting to install, remove, or adjust any piping products

Wear safety glasses, hardhat, and foot protection during installation.

Proper torqueing of bolts is required to obtain specified performance and to prevent pipe joint separation. Over torqueing may result in broken bolts or castings.

Failure to follow these instructions could result in improper product installation, property damage, and serious personal injury.

Installation:

Gaskets

Start with clean mating coupling surfaces. Remove burrs, rust, and greasy dirt on gaskets, grooves, and pipe ends. Zurn FP23 Couplings gaskets are EPDM, temperature rated -30F to 230F. Use with cold water, hot water, or air. All couplings are shipped from the factory with gaskets that are lubricated and ready to install. If during installation, re-lubrication becomes necessary, a thin coating of a silicone based lubricant may be applied to the exterior gasket sealing surfaces. Use caution to ensure foreign particles do not adhere to the lubricated surfaces.

DO NOT use with petroleum oils mineral oils, solvents, or aromatic hydrocarbons.

DO NOT use with petroleum grease.

1. Slip the gasket over the pipe. The gasket must not overhang the pipe end.

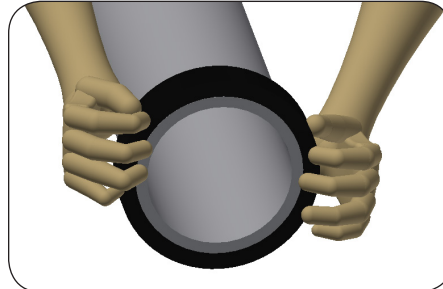

2. Align the pipe ends and pull the gasket onto the second pipe, centering it between the two grooves. It must not extend into a groove on either pipe. There must be no twist in the gasket.

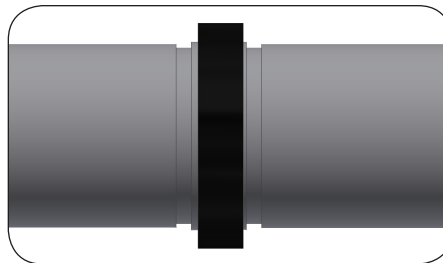

3. Place the coupling housing halves over the gasket and carefully align the housing keys to engage the grooves. Insert bolts and turn nuts hand tight.

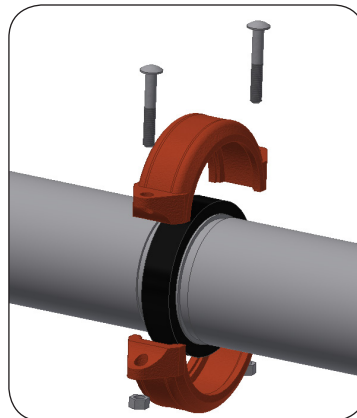

4. Alternately and equally tighten the bolts to avoid gasket pinching. Use the specified torque in the Required Assembly Torques Table.

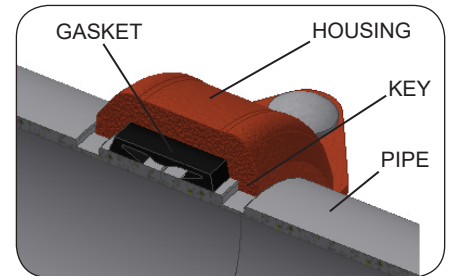

5. Engagement of the housing keys in the pipe grooves is essential to providing a secure leak-tight joint. For Rigid Couplings, keep gaps at bolt pads evenly spaced. For flexible couplings, bolt pads should be clamped iron-to-iron.

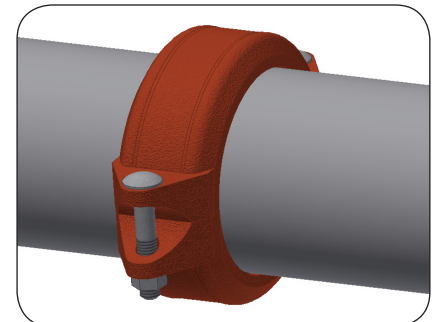

Table 4. Required Assembly Torques Table

Bolt Size	Required Torque		
	Inch	N-m	Lbs-Ft
3/8	40-60	30-45	
1/2	110-135	80-100	
5/8	135-175	100-130	
3/4	175-245	130-180	
7/8	245-325	180-240	

WARRANTY: ZURN WILKINS Valves are guaranteed against defects of material or workmanship when used for the services recommended. If in any recommended service, a defect develops due to material or workmanship, and the device is returned, freight prepaid, to ZURN WILKINS within 12 months from date of purchase, it will be repaired or replaced free of charge. ZURN WILKINS' liability shall be limited to our agreement to repair or replace the valve only.

WARNING: This product is NOT Lead Free in accordance with U.S. Federal Law and is illegal in the U.S. for use in potable services or to install in water systems anticipated for human consumption.

▲ **WARNING:** Cancer and Reproductive Harm - www.P65Warnings.ca.gov
 ▲ **ADVERTENCIA:** Cáncer y daño reproductivo - www.P65Warnings.ca.gov
 ▲ **AVERTISSEMENT:** Cancer et néfastes sur la reproduction - www.P65Warnings.ca.gov

ZURN WILKINS
www.zurn.com

1747 Commerce Way, Paso Robles, CA 93446 Phone:855-663-9876 Fax:805-238-5766