



Z5738.205.00

“The Small Pint®” 1/8 gpf, EcoVantage® Ultra Low Consumption, Battery Powered Urinal System

TAG _____



Z5738.205.00 Series

- Zurn One ultra low consumption urinal system designed for optimal performance between Zurn fixture and Zurn flush valve to save water while exceeding industry performance standards.
- 1/8 gallons per flush [0.5 Liters per flush]
- Vitreous china
- High efficiency washout flushing action
- Over 88% water savings over standard 1.0 gpf [4.0 Lpf] system
- Pressure compensating internal flow regulator
- Manual override flush activator button
- 3/4" top spud
- 2" I.P.S. outlet flange and rubber gasket with integral trap
- 14" extended rim for handicap compliance when installed at proper height
- Assembled with vandal resistant outlet strainer
- Shipping weight: 39 lbs.

ENGINEERING SPECIFICATION:

Z5738.205.00 EcoVantage® Battery Powered High Efficiency Urinal (HEU) System- System comes complete with sensor operated, battery powered exposed ZEG6003EV high efficiency flushometer valve and vitreous china urinal. The system is designed to perform to industry standards with as little as 1/8th gallon per flush. Valve is operated by an infrared convergence-type proximity sensor with smart technology, powered by 4 "AA" batteries, furnished with vandal resistant chrome plated metal housing, chloramine resistant internal seals, and reversible cover. Valve features a manual override flush activation button, an internal flow regulator to maintain constant flow rates independent of line pressures and an in-line filter to protect the valve from debris within the water. Complete with high pressure vacuum breaker, one piece hex coupling nut, adjustable tailpiece, spud coupling and flange for top spud connection. Control stop has internal siphon-guard protection, vandal resistant stop cap, sweat solder kit, and a cast wall flange with set screw. Vitreous china urinal is supplied with retrofit bracket, 3/4" top spud, 2" outlet connection, and vandal resistant outlet strainer.



Z5738.205.00 SERIES

These dimensions and specifications are subject to change without notice.

Fixture dimensions meet ANSI/ASME standards A112.19.2 and CAN/CSA B45 requirements.

Meets the American Disabilities Guidelines and ANSI A117.1 requirements when urinal is installed 17" [432 mm] from finished floor.



This space is for Architectural/engineering Approval

ZURN INDUSTRIES, LLC. ♦ COMMERCIAL BRASS OPERATION ♦ 5900 ELWIN BUCHANAN DRIVE ♦ SANFORD NC 27330
 Phone: 1-800-997-3876 ♦ Fax: 919-775-3541 ♦ World Wide Web: www.zurn.com
 In Canada: ZURN INDUSTRIES LIMITED ♦ 3544 Nashua Drive ♦ Mississauga, Ontario L4V1L2 ♦ Phone: 905-405-8272 Fax: 905-405-1292

EcoVantage® and The Pint® are registered trademarks of Zurn Industries, LLC.



Z5738.205.00

"The Small Pint®" 1/8 gpf, EcoVantage® Ultra Low Consumption, Battery Powered Urinal System Rough-In

TAG _____

Rough-in dimensions for Z5738.205.00 Series

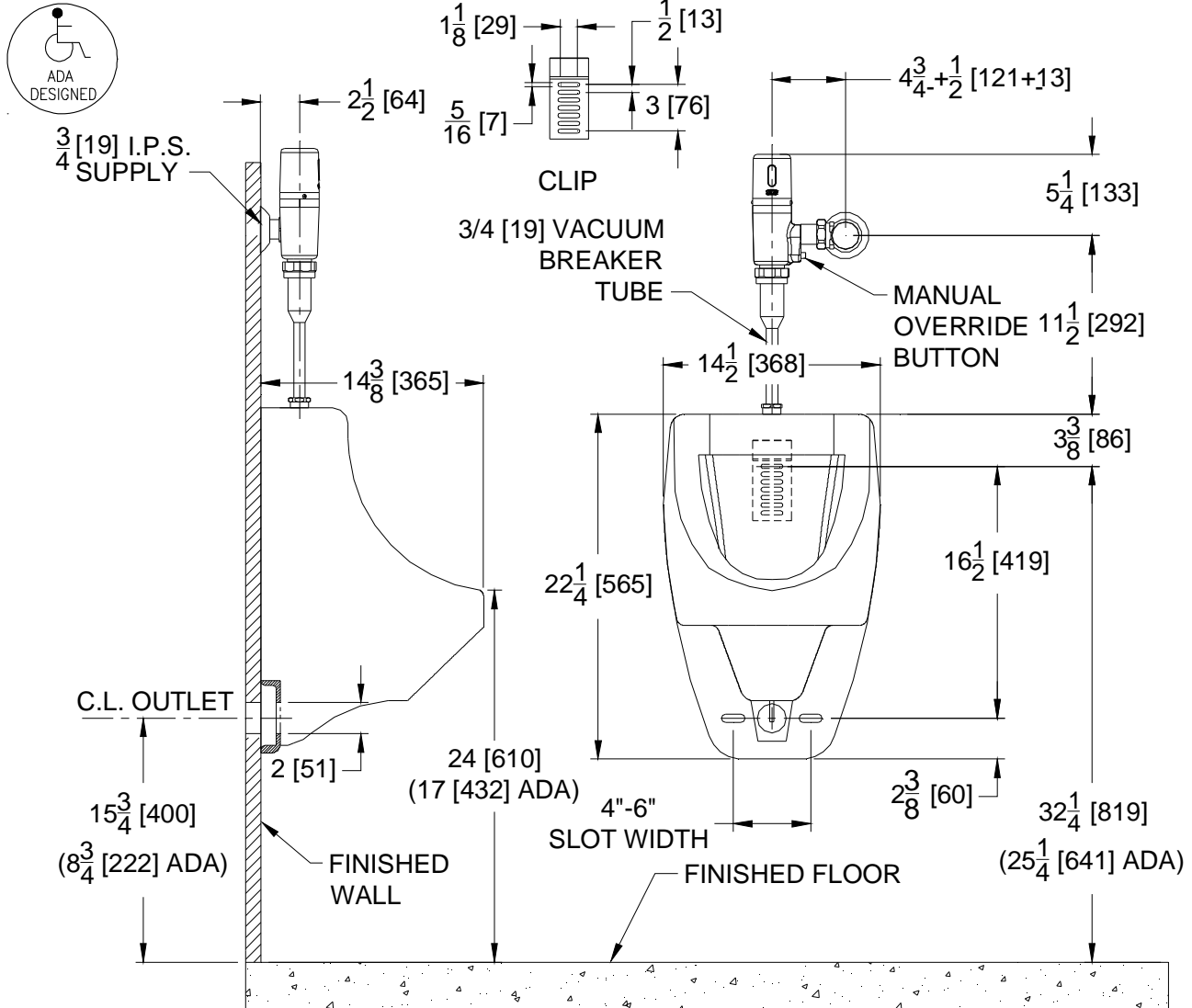

These dimensions and specifications are subject to change without notice.

Fixture dimensions meet ANSI/ASME standard A112.19.2 and CAN/CSA B45 requirements.

Meets the American Disabilities Guidelines and ANSI A117.1 requirements when urinal is installed 432mm (17") from finished floor.



Note: Rough-in for concealed plate carrier, see Zurn Z1222 Rough-in sheet.

ZURN INDUSTRIES, LLC. ♦ COMMERCIAL BRASS OPERATION ♦ 5900 ELWIN BUCHANAN DRIVE ♦ SANFORD NC 27330
Phone: 1-800-997-3876 ♦ Fax: 919-775-3541 ♦ World Wide Web: www.zurn.com

In Canada: ZURN INDUSTRIES LIMITED ♦ 3544 Nashua Drive ♦ Mississauga, Ontario L4V1L2 ♦ Phone: 905-405-8272 Fax: 905-405-1292

EcoVantage® and The Pint® are registered trademarks of Zurn Industries, LLC.