

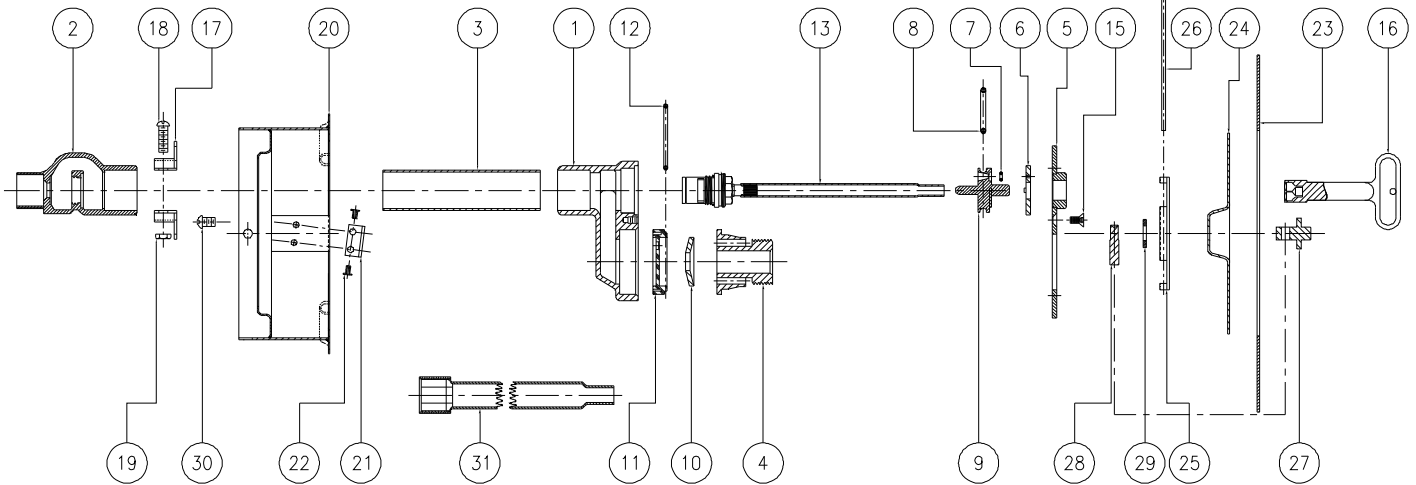

Z1322XL-EZ WALL HYDRANT ASSEMBLY

PATENTED

PAT. NO. 7,395,834

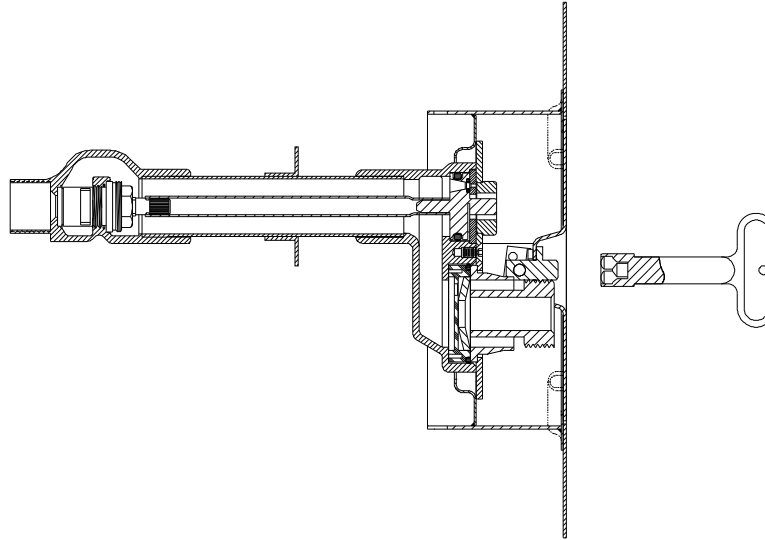

LIST OF MATERIAL

IT.	QTY	PART NO.	DESCRIPTION
1	1	59634-XL1	HEAD
2	1	59629-XL4	CARTRIDGE HOUSING
3	1	60225-XXX	CASING
4	1	50799-XL1	3/4" NOZZLE
5	1	56115-XL3	FACEPLATE
*	6	60228-001	RETAINING WASHER
*	7	23750-232	O-RING
*	8	23750-028	O-RING
*	9	60227-XL2	OPERATING COUPLING
*	10	50785-001	"EQUA-BALANCE" SEAL
*	11	50819-001	DISC
*	12	23750-204	DISC O-RING
13	1	61402-XLX	CARTRIDGE/TUBE ASSEMBLY
15	5	22698-047	FACEPLATE SCREW
*	16	59546-001	KEY

LIST OF MATERIAL

IT.	QTY	PART NO.	DESCRIPTION
17	2	56071-002	WALL CLAMP (OPT)
18	2	14853-046	CLAMP SCREW (OPT)
19	2	14850-002	CLAMP NUT (OPT)
20	1	83953-001	BODY WELDMENT
21	1	52033-002	LOCK CLIP
22	2	56201-002	LOCK CLIP RIVET
23	1	83950-001	FRAME
24	1	83949-002	HYDRANT COVER
25	1	83954-001	HINGE BRACKET
26	1	58483-001	HINGE PIN
27	1	25306-001	LOCKING PIN MOUNTING
28	1	25307-001	LOCKING PIN
29	1	61631-001	WASHER
30	2	14853-042	SCREW #10-24 N.C.
31	1	62078-XXX	CARTRIDGE WRENCH (OPT)

* ITEMS ARE AVAILABLE IN -RK REPAIR KIT OPTION BAG #66955-340-9.