



# Connected AquaSense® Battery Powered Flush Valve ZTR Series -W2 Installation, Operation, Maintenance and Parts Manual Patented and Patents Pending



### Water Closet Models:

ZTR6200-ONE-W2	1.1 gpf
ZTR6200EV-W2	1.28 gpf
ZTR6200-WS2	1.6 gpf

### Urinal Models:

ZTR6203-ULF-W2	0.125 gpf
ZTR6203-QRT-W2	0.25 gpf
ZTR6203-EWS-W2	0.5 gpf
ZTR6203-WS1-W2	1.0 gpf

- ⚠ **WARNING:** Cancer and Reproductive Harm - [www.P65Warnings.ca.gov](http://www.P65Warnings.ca.gov)
- ⚠ **ADVERTENCIA:** Cáncer y daño reproductivo - [www.P65Warnings.ca.gov](http://www.P65Warnings.ca.gov)
- ⚠ **AVERTISSEMENT:** Cancer et effets néfastes sur la reproduction - [www.P65Warnings.ca.gov](http://www.P65Warnings.ca.gov)

### LIMITED WARRANTY

All goods sold hereunder are warranted to be free from defects in material and factory workmanship for a period of three years from the date of purchase. Decorative finishes warranted for one year. We will replace at no costs goods that prove defective provided we are notified in writing of such defect and the goods are returned to us prepaid at Sanford, NC, with evidence that they have been properly maintained and used in accordance with instructions. We shall not be responsible for any labor charges or any loss, injury or damages whatsoever, including incidental or consequential damages. The sole and exclusive remedy shall be limited to the replacement of the defective goods. Before installation and use, the purchaser shall determine the suitability of the product for his intended use and the purchaser assumes all risk and liability whatever in connection therewith. Where permitted by law, the implied warranty of merchantability is expressly excluded. If the products sold hereunder are "consumer products," the implied warranty of merchantability is limited to a period of three years and shall be limited solely to the replacement of the defective goods. All weights stated in our catalogs and lists are approximate and are not guaranteed.

**NOTICE: READ ENTIRE MANUAL PRIOR TO INSTALLING PRODUCT**

# ZTR Series Flush Valve Package Contents

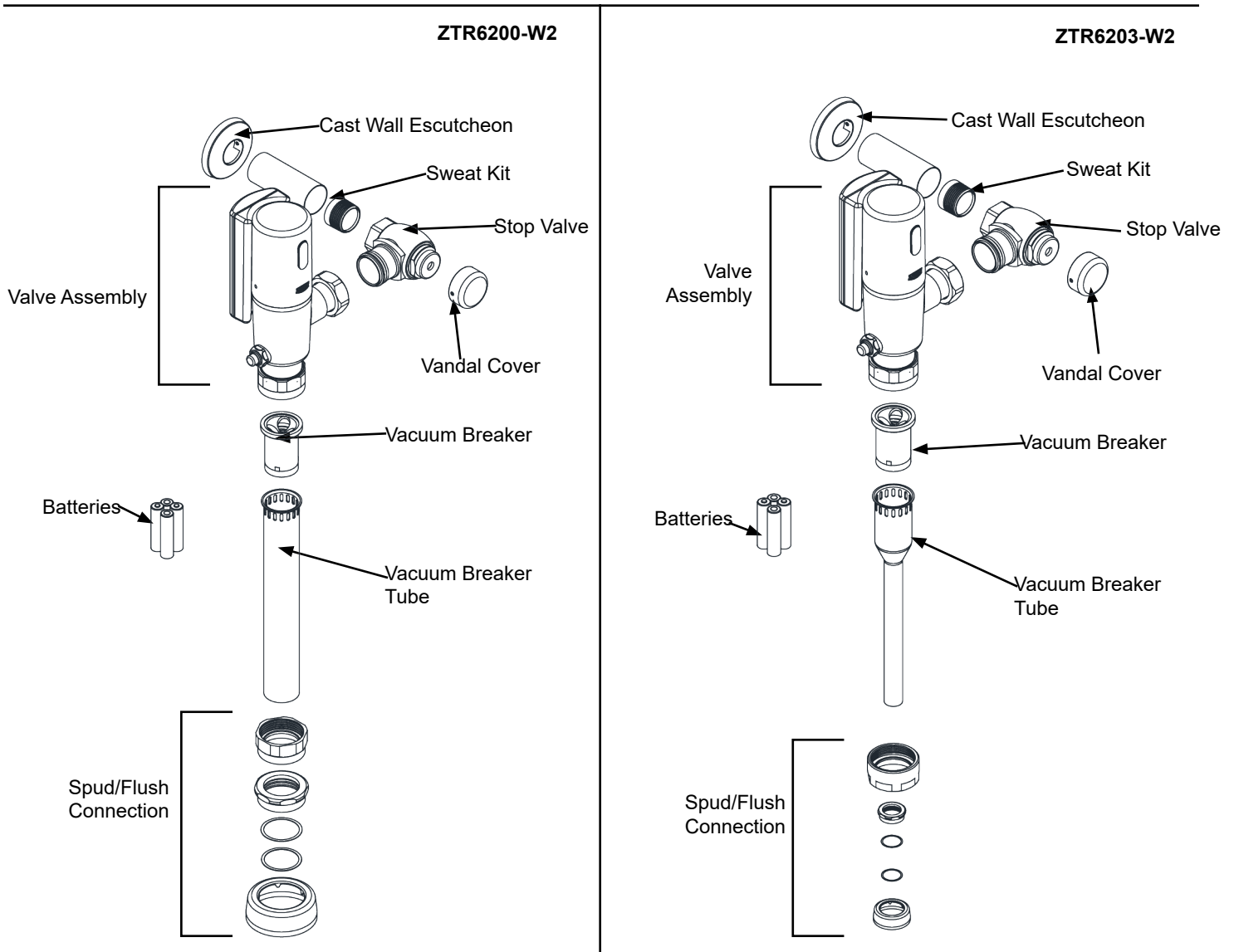

## Required Tools

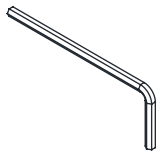

3/32", 5/64"  
Allen Wrench

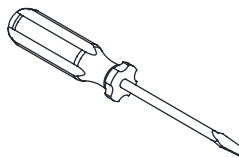

Flat Head  
Screwdriver

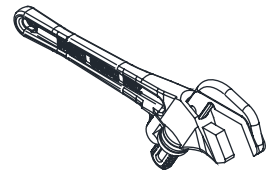

Smooth Jawed  
Wrench

## Optional Accessories



Magic Magnet  
P6900-AT-MAG

## Overview:

Zurn connected flush valves transmit data 24/7 to the Zurn plumbSMART™\* web portal and mobile app. Proactively monitor your flush valve activations and water usage, receive real-time alerts for preset high and low usage parameters, and access system data for trends and predictive maintenance anytime and anywhere.

AquaSense® sensor flush valves are ideal for high-use applications where durability and hands-free operation are necessary. ADA compliant, battery powered, sensor operated for retrofit and new construction. Unit is furnished with a clog resistant piston and manual override button. Standard battery-powered is 4 “AA” batteries with a 3-year life, Long life battery-powered is 4”AA” batteries with a 10-year life.

## Specifications:

Voltage: 6 VDC Series [4 “AA” (Alkaline or Lithium)]

Sensor Range: Factory set for user at end of elongated bowl or field adjustable by installer

## Important Safety Information:

- Installer is responsible for ensuring the product is installed and conforms to all plumbing codes and ordinances.
- Do not convert or modify this Zurn product yourself. All warranties will be voided.
- Water supply lines must be sized according to building designer in order to provide adequate water supply for each fixture.
- Flush all water lines prior to making connections.

## Prior to Installation:

- The ZTR flushometer is designed to operate optimally between 25 psi (running) to 80 psi (static) water pressure (172 to 552 kPa). Higher running pressure may be required for some fixtures. Consult fixture manufacturer for details.
- When installing a flushometer, it is important that the flush volume matches the requirements of the plumbing fixture.
- To protect chrome finish, do not use toothed tools to install or service the flushometer.
- Before installing your Zurn® Sensor Flush Valve: the items listed below should already be installed on site.
  - Closet
  - Fixture carrier
  - Drain line
  - Water supply line

**NOTE:** The information in this manual is subject to change at any time without notice. Installations may be performed at different times of construction by different individuals. For this reason, these instructions should be left on-site with the facility or maintenance manager.

# Sweat Solder Adapter Installation Instructions

**NOTE: Before installation, turn off water supplies to existing fixture and remove flushometer if replacing an existing device.**

1. Measure distance from finished wall to the center line of the fixture spud. If necessary, cut water supply pipe 1-1/4" shorter than this measurement. Deburr by chamfering O.D. and I.D of end of water supply pipe.

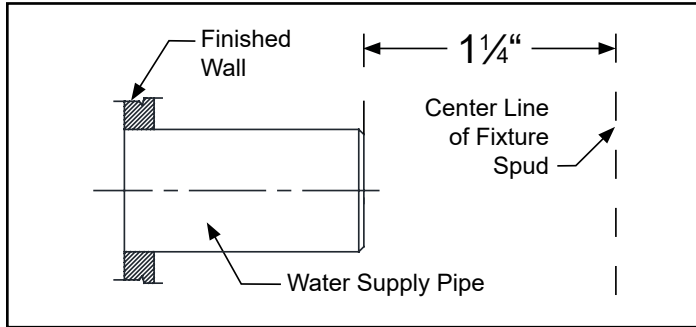

2. Slide threaded sweat solder adapter onto water supply pipe until shoulder stops on end of pipe. Then sweat-solder the adapter to water supply pipe.

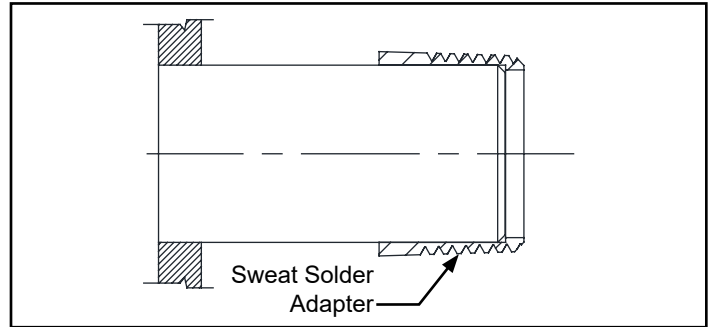

3. Measure distance from finished wall to first thread of sweat solder adapter. If necessary, cut chrome cover tube this length.

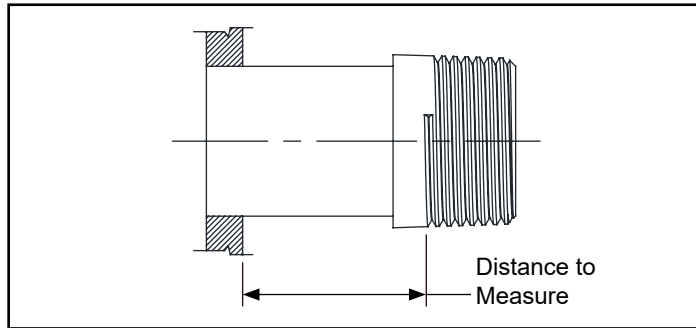

4. Slide wall escutcheon over chrome cover tube and slide both items over water supply pipe. Press wall escutcheon flush against finished wall and tighten set screw with hex wrench (supplied) to secure it in place.

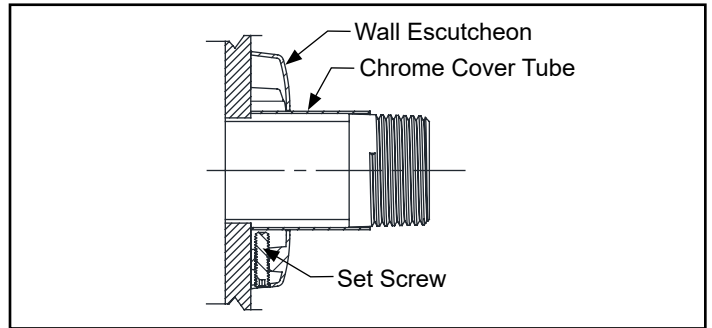

# Control Stop Installation Instructions

1. Install control stop assembly by threading it onto water supply pipe and tightening with a smooth jawed wrench. Apply thread sealing compound or pipe tape to male NPT thread on sweat solder adapter only.

Prior to turning on main water supply line ensure all stop valves are closed off tight by using a flathead screwdriver and turning the stop valve adjustment screw clockwise.

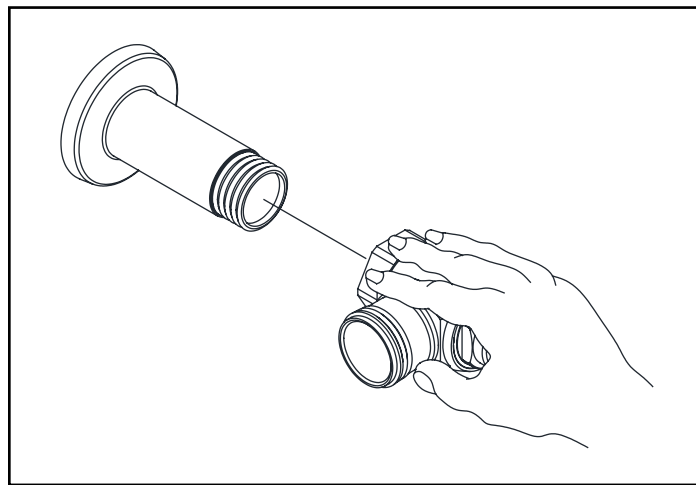

2. When all stop valves are properly connected to the water supply line and water pressure is available, open the control stop using a flat head screwdriver and turning the stop valve adjustment screw counterclockwise.

Allow the water supply line to flush any debris or sediment that may be present in the line. Close the control stop once the lines are completely flushed.

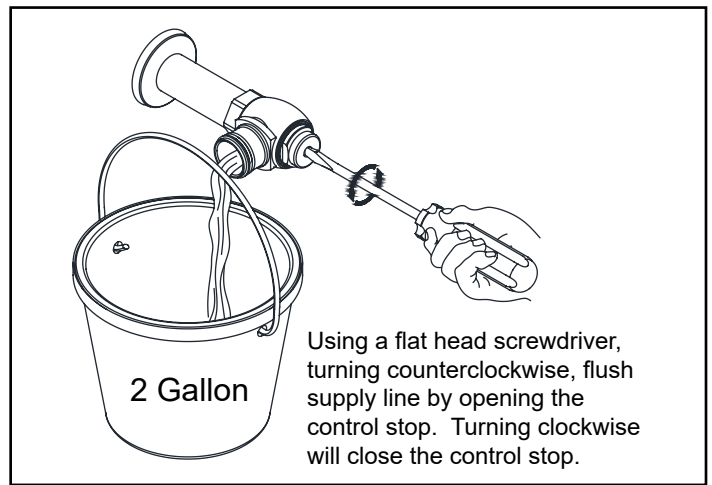

## Flush Valve Installation Instructions

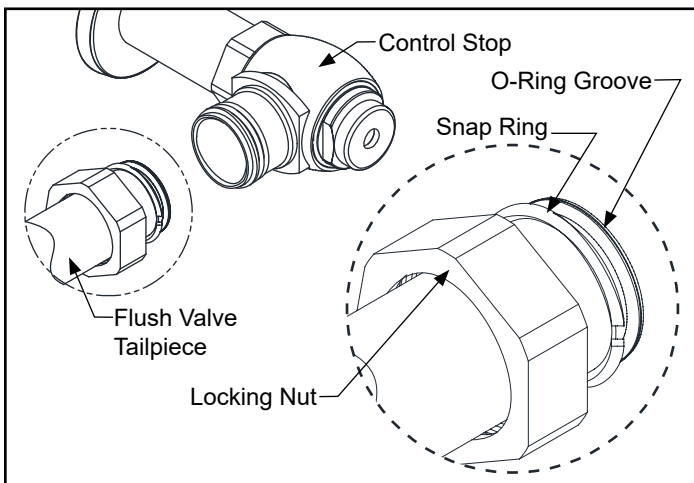

Prior to attaching flush valve tailpiece to control stop, inspect and verify that the O-ring seal is located within the O-ring groove at the tailpiece. Ensure that the locking nut and locking snap ring are also present on the tailpiece.

Lubricate O-ring with water if necessary and insert flush valve tailpiece into the control stop valve. Tighten locking nut using a smooth jawed wrench.

## Vacuum Breaker & Flush Connection Installation Instructions

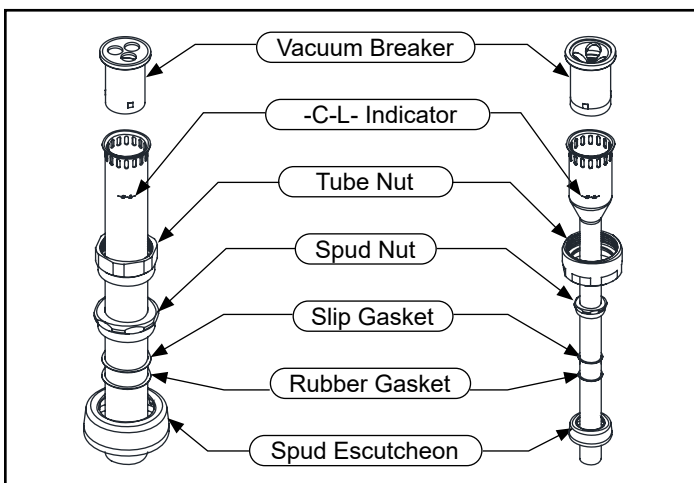

Determine the length of vacuum breaker tube required to join the flush valve and fixture spud, and cut if necessary.

Slide the tube nut, spud nut, slip gasket, rubber gasket and spud escutcheon over the vacuum breaker tube and insert tube into fixture spud. Hand tighten tube nut to valve body and hand tighten spud nut onto fixture spud. Adjust the valve assembly for plumb. Tighten fixture spud nut, vacuum breaker tube nut and locking nut with a wrench.

Adjust and plumb the valve assembly. Tighten all connections with smooth jawed wrench and turn on water supply at the control stop.

**⚠ DO NOT** cut vacuum breaker tube shorter than 6" below the -C-L- indicator mark, as vacuum breaker must be 6" above the fixture. Consult plumbing Codes & Regulations for specific details.

# Battery Installation Instructions

1. Use the 3/32" Allen Wrench to loosen the internal set screw until it stops. Screw will retract into the base to eliminate loss. Rotate sensor cap clockwise and pull cap up to remove. Disconnect black solenoid plug before accessing batteries.

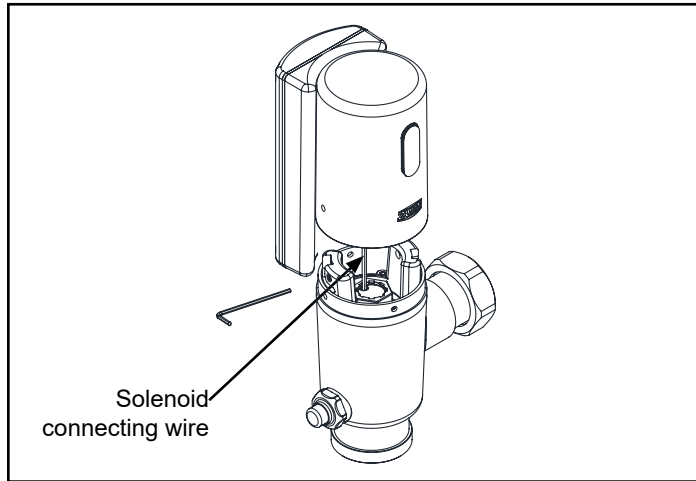

2. Loosen and remove the 4 mounting screws from the back of monitor housing and remove back panel. Install supplied batteries and reinstall back panel onto monitor housing. Tighten mounting screw.

**!** Only use one battery type for installation. **DO NOT** mix and match Standard (Alkaline) and Long Life (Lithium) Batteries.

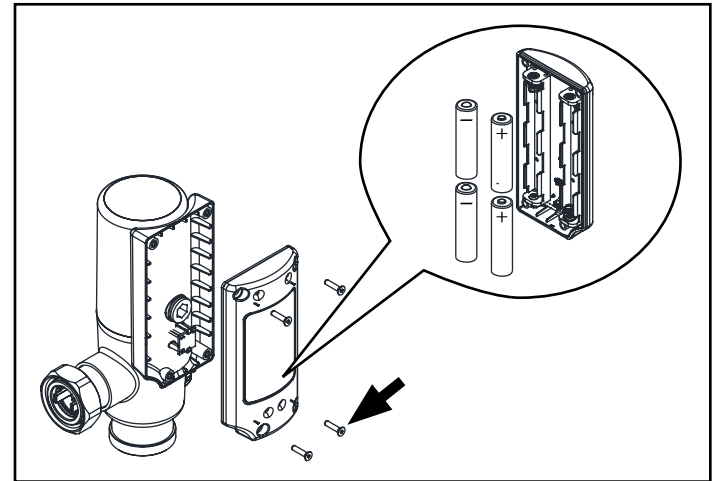

3. Connect monitor to sensor lens via RED connectors by aligning arrows and pressing together. Connect solenoid to sensor lens via BLACK connectors by aligning arrows and pressing together. Utilize open space within the sensor cap to store the connected RED power connectors and BLACK solenoid connectors.

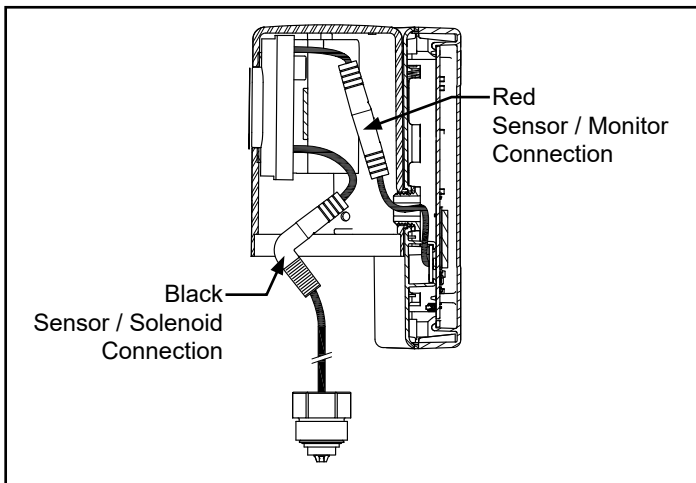

# Connected Sensor Cap Retrofit Installation Instructions

1. Remove vandal-resistant cover with allen wrench from control stop (if present) and turn control stop clockwise to turn off the water supply.

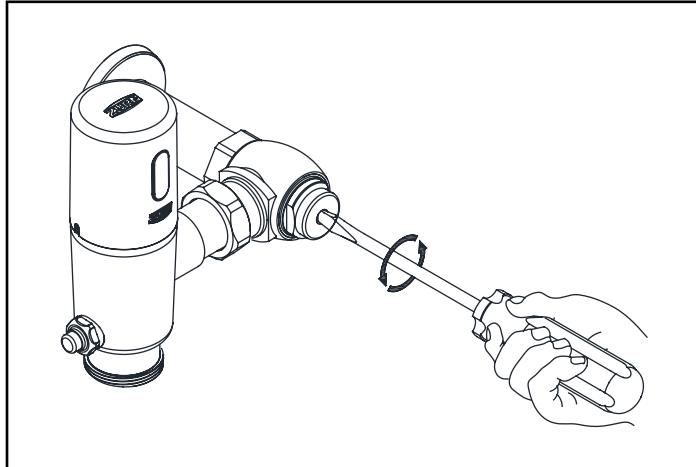

2. Press and hold the manual override button for 3 seconds to release any residual pressure.

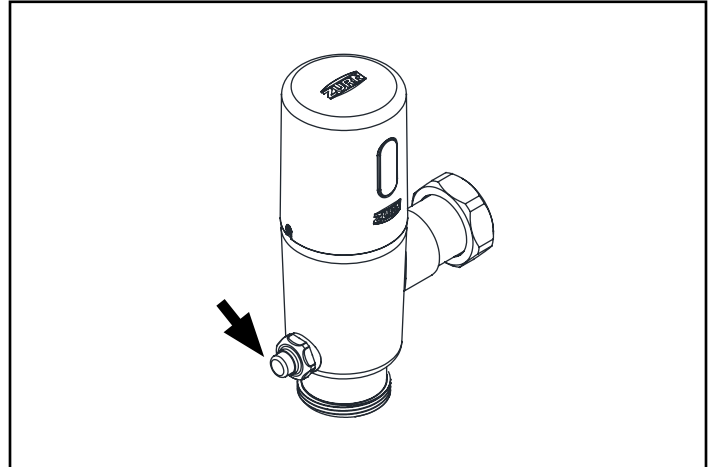

3. Use a 5/64" allen wrench to remove the two cap screws from the sensor cap and remove the sensor cap. Disconnect black solenoid plug shown below.

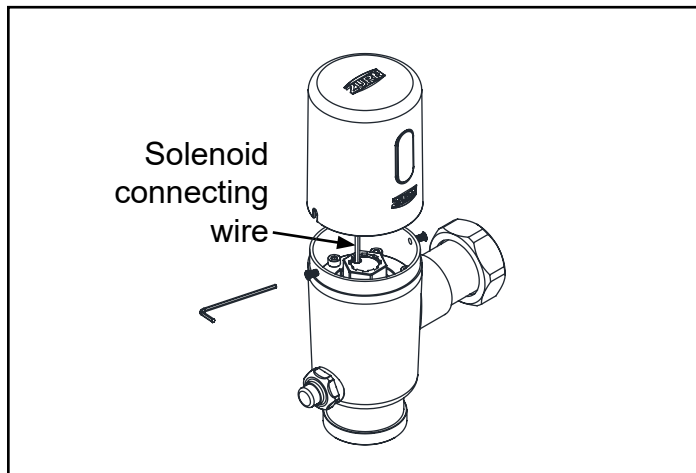

4. Remove the 4 sockets screws shown using a M3 allen wrench and discard the screws

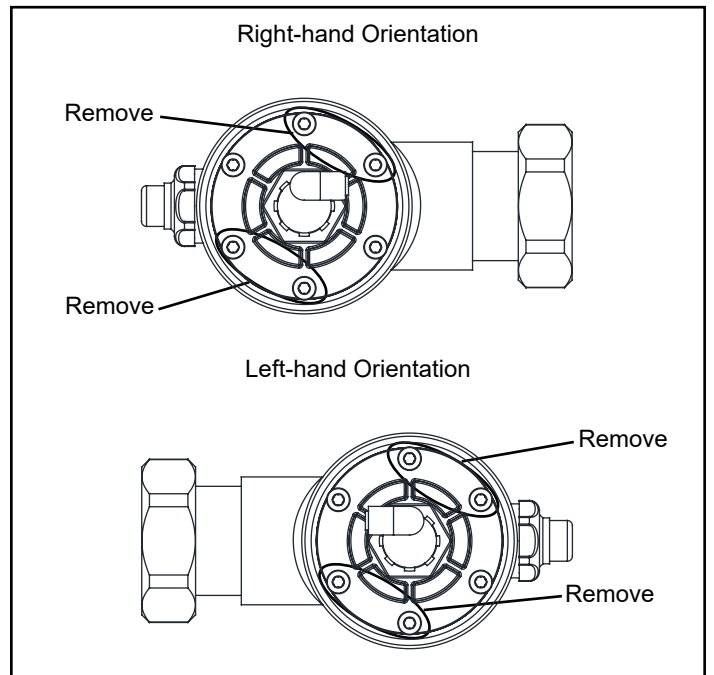

5. Note socket screw pockets in the ring insert and place over remaining 2 socket screws See Figure below.

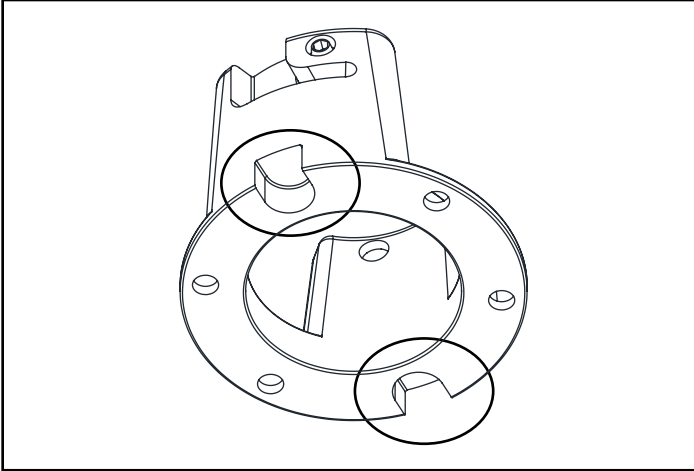

6. Ensure ring insert set screws align with valve body holes shown in Figure below. Hand start the 4 new sockets screws(included) into the ring insert. Tighten screws in the torque sequence shown on Figure on Tightening sequence.

Then, Follow steps 2 & 3 from Battery installation Instructions Section.

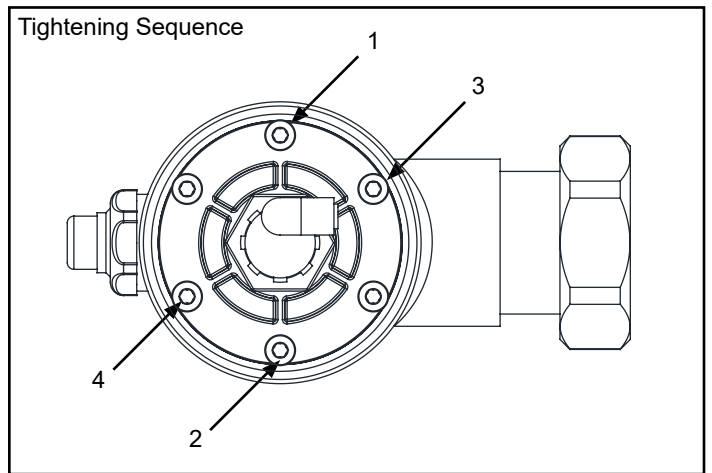
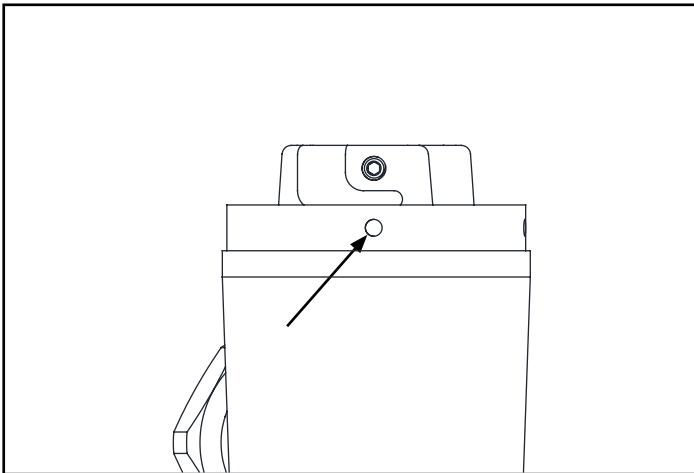

7. Align set screw hole in sensor cap with key way in ring insert and place sensor cap on valve body.

Rotate sensor cap counter clockwise until the set screw is visible in the sensor cap hole and the sensor is facing forward. Using the 3/32" allen wrench(provided) rotate the set screw clockwise to secure the cap.

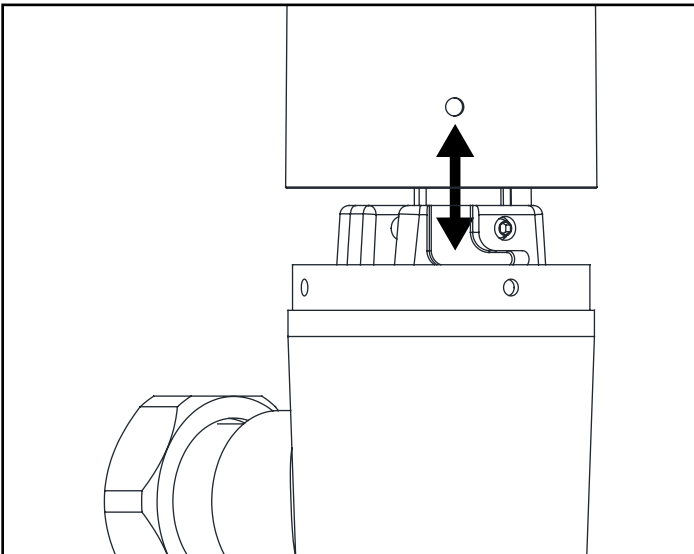



## Dip Switch Settings (when necessary)

### Courtesy Flush

A courtesy flush can be enabled for the ZTR flushometer where the valve will automatically flush at a specified interval based on customer preference. Simply manipulate Dips witches #2 and #3 located on the Sensor Lens found on the inside of the Sensor Cap to change the courtesy flush interval.

Courtesy Flush Interval	Dipswitch #2	Dipswitch #3
Disabled (Default Setting)	ON	ON
24 hours	ON	OFF
48 hours	OFF	ON
72 hours	OFF	OFF

### Dual Flush Option (If Equipped)

The dual flush option can be enabled by turning switch #1 to the **ON** position.

Note: The ZTR Dual Flush must be originally ordered with the dual flush option. Regular single flush valves will not function in dual flush mode.

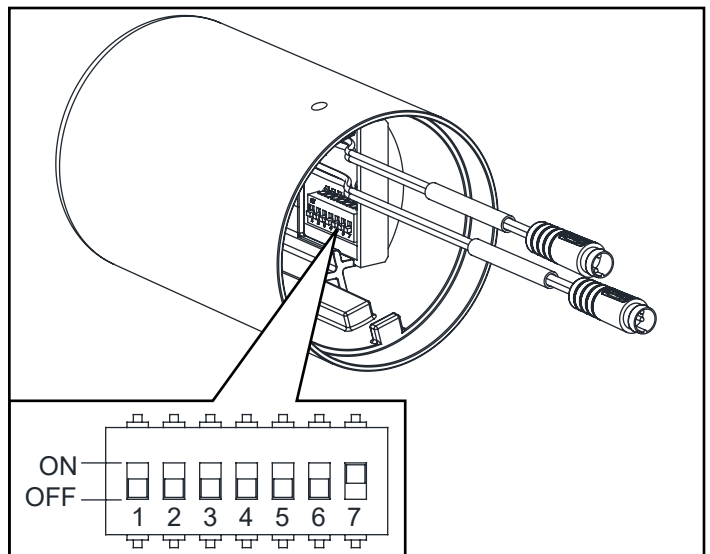

## Sensor Range Adjustment (when necessary)

### STEP 1.1

Place the Zurn Magic Magnet (optional accessory: P6900-AT-MAG) against the cap at the lower right corner of the Zurn logo under the sensor lens. Hold in place until the valve automatically flushes and the red LED light flashes two(2) times. Remove Magic Magnet from flush valve. The valve has entered calibrate mode

### STEP 1.2

Place light-colored target at desired detection range away from sensor. After 10 more LED flashes followed by a double flash and/or flush the new detection range will be calibrated and set.

**⚠** Test new calibrated sensor range using targets of various material types/textures to ensure calibration accuracy. Verify that sensor range does not detect stall doors or other reflective surfaces.

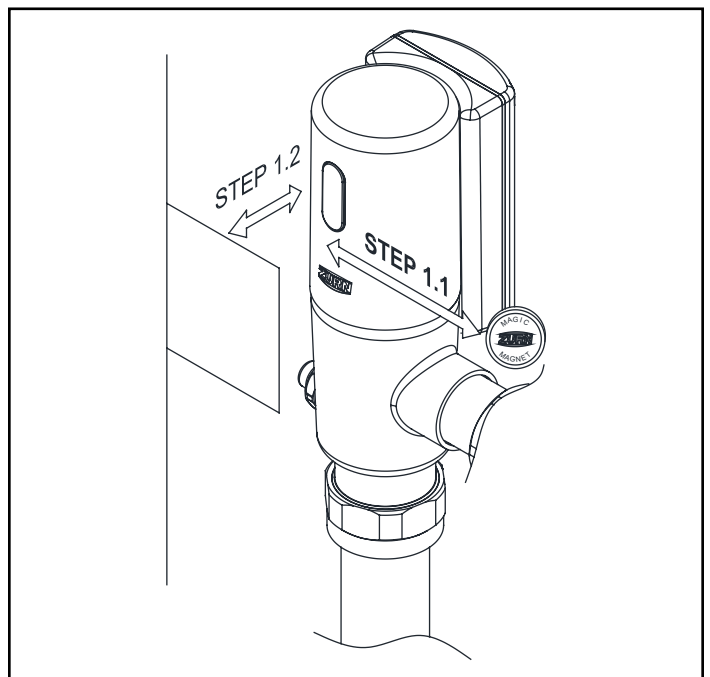

## Care and Cleaning Instruction

- Do not use any abrasive or chemical cleaners to clean the flushometer.
- ONLY use mildly warm soapy water, and then wipe the device dry with a clean/soft towel or cloth.
- Upon cleaning other areas of the restroom, be sure the sensor lenses are protected from other cleaning chemicals/solvents to prevent potential damages to the sensor and/or electronics.

### Accessing Piston Kit

1. Turn off water supply and press manual override button to relieve all water pressure.
2. Remove valve cap to expose ring insert. Using the M3 Allen Wrench remove the 4 screws and the ring insert.
3. Remove the remaining 2 screws and the solenoid flange.
4. Remove the piston kit from the valve body and inspect for damage to the seals or debris in the orifice. Excessive build up of debris may occur on filter screen.

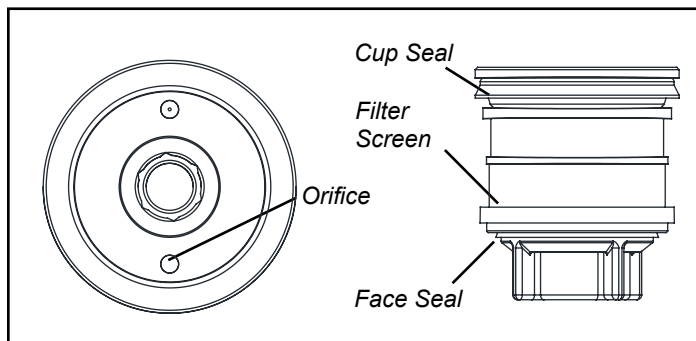

## Gateway Instruction

### Step 1. Request Gateway:

You can request your Ethernet or LTE gateway by visiting

[Zurn.com/plumbsmart-gateway-request](https://www.zurn.com/plumbsmart-gateway-request)

or call Zurn Customer Care at 1-844-987-6737

### Step 2. Cabling, Powering and Connecting Your Device:

1. Connect one end of the RJ45 Ethernet cable (supplied) to the gateway's Ethernet port and plug the cable's other end into the nearest wall port of the building's Ethernet network.
2. Connect the power supply to the power jack.
3. Wait for status LED to go from ON to double flash every second, the LoRa LED to turn ON solid, and the cell LED (if LTE enabled) to flash once every 3 seconds. Should take around 1-2 minutes depending on location. Your gateway is now ready to transmit data from your Zurn connected product.
4. Zurn Gateways have been set to DHCP by default. Please consult local IT support for possible additional access requirements for your network.

### Step 3. Determining general Location for the Zurn Gateway:

- Select a location central to all devices to be connected to this gateway. Place the gateway as high as possible, such as near the top of a wall.
- Avoid obstructions. Thick walls and reflective surfaces, such as metal, weaken the signal between the gateway and other devices.
- The LoRa antenna is an omni-directional antenna, but for best results, mount the device so the LoRa antenna is in a vertical position near the top of a wall. We recommend conducting a site survey to test the signal strength in different locations before you mount the device.

### Step 4. Mounting the Zurn Gateway:

The device ships with a mounting bracket. You will also need:

- Four #6 screws with anchors
  - Screwdriver
  - Drill
1. Determine where you want to mount the device.
  2. Mark where you want the screws to go.
  3. Drill holes for the screws and insert anchors.
  4. Place the mounting bracket and secure it with screws.
  5. Attach the device to the bracket and rotate to lock into place.

## Register in plumbSMART

NOTE: Instructions below are duplicated from registration card supplied with monitor



1. Install Zurn Connected Product(s)
2. Install Zurn Gateway per the Gateway Instructions Manual
3. Request plumbSMART Administrator Account at 844-987-6737
4. Zurn creates your Enterprise Account for you! (You will be required to identify your building location, number of floors, and number of rooms.)
5. Log in to [plumbsmart.zurn.com](https://plumbsmart.zurn.com)
6. Register each Connected Product in plumbSMART (Watch How-To Videos to Get Started. Located in the support section inside the portal.)
7. Now, Relax. You're Connected.

# Flush Valve Trouble Shooting Guide

PROBLEM	INDICATOR	POTENTIAL CAUSE	SOLUTION
Valve does not flush	No lights on sensor board	Batteries not making contact	Remove and reinstall batteries correctly - See step 5A for reference
		Batteries reversed polarity	
	Sensor flashes (red) every 10 seconds	Low battery voltage indication	Replace batteries - see Step 5A for reference
	Sensor flashes (red) every 30 seconds	Continuous target detection of object within sensor range	#1 Inspect and clean lens
			#2 Identify and remove any target from sensor field
			#3 Reduce sensor range distance (see page 10 for Sensor Range Adjustment instructions).
	Sensor detects user but fails to flush upon exiting sensor range	Batter power level too low to activate full flush - sensor board automatically shuts down to avoid open flush	Replace batteries See Step 5A for reference
Dirty sensor lens		Clean lens until free of debris	
Loose or damaged solenoid connection		Inspect connection between solenoid and sensor for proper insertion - step 4	
No target detected	Install environment may require adjustment of the sensor range from the factory settings	Re-calibrate sensor range - see Sensor Range Adjustment (Figure 28) page 10	
Valve does not shut off water (continuous flow)	Normal target detection	Water pressure either too high or too low	Adjust water pressure to recommended range: 35 to 80 psi running water pressure
		Piston and / or solenoid plugged or damaged	Remove Piston and / or Solenoid to examine for damage or plugging. Clean piston / solenoid orifice if plugged. Replace solenoid kit if solenoid diaphragm is damaged.
		Low or no power allowing solenoid to move to open position but not enough power to return to closed position.	Replace batteries or restore power if hardwired.
		MOB (mechanical override button) sticking in open position	Replace MOB.
Valve flows low (short flushing)	Valve does not evacuate fixture	Tailpiece filter is clogged with debris	#1 Turn stop off #2 Remove valve from stop and fixture #3 Inspect/clean filter (see parts breakdown - Part number 10)
		Piston orifice is enlarged	Replace piston
		Flush valve rating does not match fixture flush rating	Replace flush valve to match fixture flush rating
Ghost flushing	Flush valve activates without target present.	Highly reflective environment	Re-calibrate sensor range - see Sensor Range Adjustment
		Sensor range set too far, picking up other objects.	
Continuous flushing	Valve flushes every 30 seconds.	Magnet stored in sensor cap.	Remove magnet from sensor cap. Do not store magnet in flush valve.
Electronic Control Board	Cannot adjust sensor range	Processor latched	Reset electronics module by removing cap, disconnect power connector and shorting terminals together. Reconnect power, allowing 30 seconds to complete power up sequence.
	DIP switch settings	Configuration changes to DIP switches	Remove cap from valve and disconnect power. Move DIP switch to desired position. Reconnect power, allowing 30 seconds to complete power up sequence.

For further assistance with troubleshooting, visit <http://www.zurn.com/>

# Trouble Shooting: LoRa Monitor

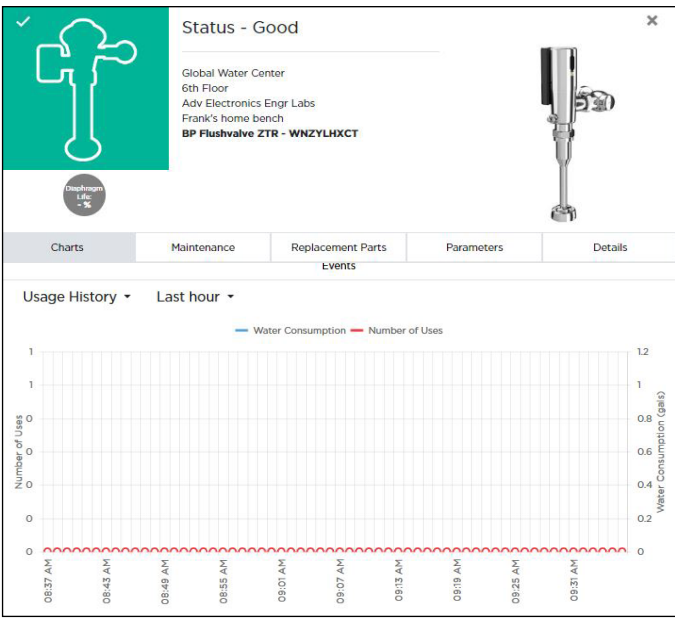
Problem	Corrective Action
<p><b>“Device Not Communicating”</b> posted in plumbSMART</p> 	<p><b>Step 1</b> Verify batteries installed in LoRa Monitor electronics and have sufficient charge. Install new batteries, as needed. Alert on product’s page in plumbSMART should clear within 1 hour or on next faucet activation. (Refresh web page by clicking on reload icon in the browser to clear the alert.)</p> <p><b>Step 2</b> If problem still present, verify gateway is within range of LoRa Monitor and functioning (see Gateway Troubleshooting section)</p> <p><b>Step 3</b> If problem still present, verify plumbSMART subscription status on product page’s Details tab listed as “Activated”</p> <p><b>NETWORK:</b> Senet <b>SUBSCRIPTION STATUS:</b> <i>Activated</i> <b>LAST HEARD FROM:</b> 07/14/2020, 04:29 PM CDT</p> <p>If listed as “Deactivated”, contact Zurn Custom Service at 1.855.ONE.ZURN (1.855.663.9876) for assistance.</p>
<p><b>“Status – Good”</b> posted in plumbSMART and faucet not actuating</p> 	<p><b>Step 1</b> Verify LoRa Monitor’s cables are connected to IR sensor and Faucet actuator electronics. Restore proper electrical connection, as needed.</p> <p><b>Step 2</b> Test activate the faucet.</p> <p>If problem persists, see Faucet Troubleshooting section in this guide for other steps.</p>
<p><b>“Status – Good”</b> posted in plumbSMART and faucet actuates but usage event data not appearing in plumbSMART Charts</p> 	<p><b>Step 1</b> Verify gateway is powered and LoRa Status LED is ON. If not, apply power per Zurn Gateway Installation Guide or see Gateway Troubleshooting section in this guide of other steps.</p> <p><b>Step 2</b> If problem still present, verify plumbSMART subscription status on product page’s Details tab listed as “Activated”</p> <p><b>NETWORK:</b> Senet <b>SUBSCRIPTION STATUS:</b> <i>Activated</i> <b>LAST HEARD FROM:</b> 07/14/2020, 04:29 PM CDT</p> <p>If listed as “Deactivated”, contact Zurn Customer Service at 1.855.ONE.ZURN (1.855.663.9876) for assistance.</p> <p><b>Step 3</b> If problem still present, the LoRa Monitor electronics may be faulty. Contact Zurn Customer Service at 1.855.ONE.ZURN (1.855.663.9876) for assistance with additional troubleshooting steps and, if needed, unit replacement.</p>

For further assistance with troubleshooting, visit <https://plumbsmart.zurn.com/app/training>

# Trouble Shooting: Gateway

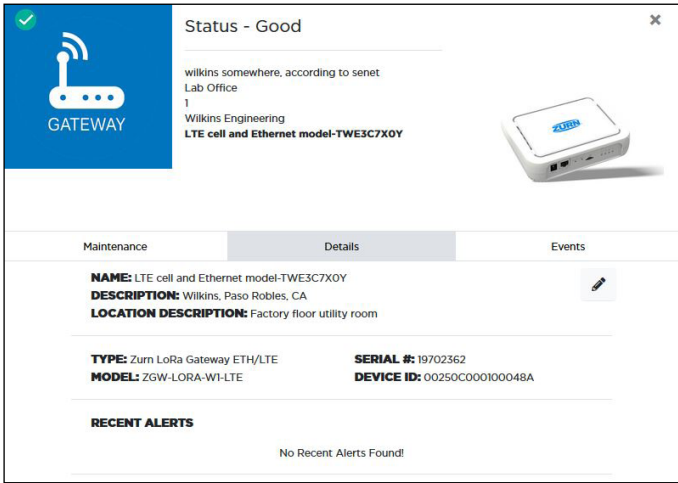
Problem	Corrective Action
<p>“Status – Good” posted in plumbSMART and faucet actuation event data not appearing in plumbSMART (&lt; 2 hours) or “Device Not Communicating” warning or severe alert posted in plumbSMART for all devices (&gt; 3 hours)</p> 	<p><b>Step 1</b> Verify gateway Status LED flashes twice every 2 seconds. If LED is OFF or ON solid, power cycle the gateway and wait for no more than 5 minutes for unit to initialize and connect.</p> <p><b>Step 2</b> After initialization is finished, LORA LED should turn ON solid within an additional minute.</p> <p><b>Step 3</b> If LORA LED does not turn ON solid and ethernet cable connected, contact facility IT administrator to modify port rules to allow Zurn gateway to access the internet via local router.</p> <p>If gateway model is ETH/LTE, visually verify SIM card is installed in designated slot on the side of gateway. If unit has a SIM card, then disconnect ethernet cable and power cycle the gateway and wait for unit to initialize and connect. LORA LED should turn ON solid after initialization.</p> <p><b>Step 4</b> If problem still present, move gateway closer to LoRa monitors and/or verify gateway mounting, orientation and connections comply with requirements listed in Zurn Gateway Installation Guide.</p> <p>Contact Zurn Customer Service at 1.855.ONE.ZURN (1.855.663.9876) for assistance with additional troubleshooting steps.</p>

For further assistance with troubleshooting, visit <https://plumbsmart.zurn.com/app/training>

# Trouble Shooting: plumbSMART

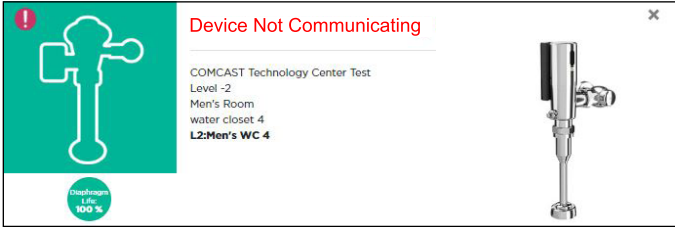
Problem	Corrective Action
<p>Usage data presented in Water Usage Chart does not match expected usage.</p>	<p><b>Step 1</b> Confirm installed aerator model's gallons/minute specification matches parameter setting in plumbSMART product page "Parameters" tab. If factory-original aerator is installed, reset parameter value to factory default and click Update.</p> <div data-bbox="829 352 1422 506" style="border: 1px solid black; padding: 5px;"> <p><b>DIAPHRAGM FLUSH RATE</b> </p> <p>Flow per Flush </p> <p style="text-align: right;">1.0 gpf (Default: 1.0)</p> <p style="text-align: right;"><input type="button" value="Reset to Defaults"/> <input type="button" value="Update"/></p> </div> <p><b>Step 2</b> Test activate the flush valve and confirm single usage event data is properly presented in Chart</p> <p><b>Step 3</b> If problem still present, contact building maintenance to verify sufficient water pressure in lines.</p> <p><b>Step 4</b> If problem persists, the LoRa Monitor may be paired to the incorrect fixture model. Verify product image and model number from plumbSMART product page "Details" tab against model number cited on product literature and packaging.</p> <p>If incorrect, contact Zurn Custom Service at 1.855.ONE.ZURN (1.855.663.9876) for assistance.</p>
<p>"High Daily Flush Rate" posted in plumbSMART</p> <div data-bbox="115 1052 786 1276" style="border: 1px solid black; padding: 5px;">  <p>The screenshot shows a red error message: "Device Not Communicating". Below the message, it lists the location: "COMCAST Technology Center Test, Level -2, Men's Room, water closet 4, L2:Men's WC 4". On the right side of the message box is an image of a flush valve. At the bottom left of the message box, there is a green circular icon with a white exclamation mark and the text "Onsite Design 100%".</p> </div>	<p><b>Step 1</b> Verify flush valve is not falsely triggering. See Flush valve Troubleshooting section for appropriate diagnostic steps.</p> <p><b>Step 2</b> Test activate the flush valve and confirm single usage event data is properly presented in Chart.</p> <p>If problem persists, see Flush valve Troubleshooting section in this guide for additional steps.</p>
<p>LoRa Monitor not listed in plumbSMART.</p>	<p><b>Step 1</b> Follow registration steps in plumbSMART to activate the connected product.</p>

For further assistance with troubleshooting, visit <https://plumbsmart.zurn.com/app/training>

# Connected ZTR6200 Series Parts Breakdown

## Parts Identification

1. Ring Insert Assembly
2. Connected Valve Cap/Sensor Assembly
3. Solenoid
4. Piston Cover Screws
5. Solenoid Kit
6. Flange O-rings
7. Piston Kit
8. Valve Housing
9. Manual Override Button
10. Filter
11. Valve Assembly
12. Vacuum Breaker
13. Vacuum Breaker Tube
14. Vacuum Breaker Tube Nut
15. Spud Nut
16. Spud Friction Washer
17. Spud Sleeve
18. Spud Escutcheon
19. Setscrew for Control Stop Cover
20. Vandal-Resistant Control Stop Cover
21. Stop Cap Bonnet
22. Stop Internals
23. Piston Seal
24. Stop Body
25. Sweat Solder Adapter
26. Supply Cover Tube
27. Setscrew for Cast Wall Escutcheon
28. Cast Wall Escutcheon
29. Hex Wrench

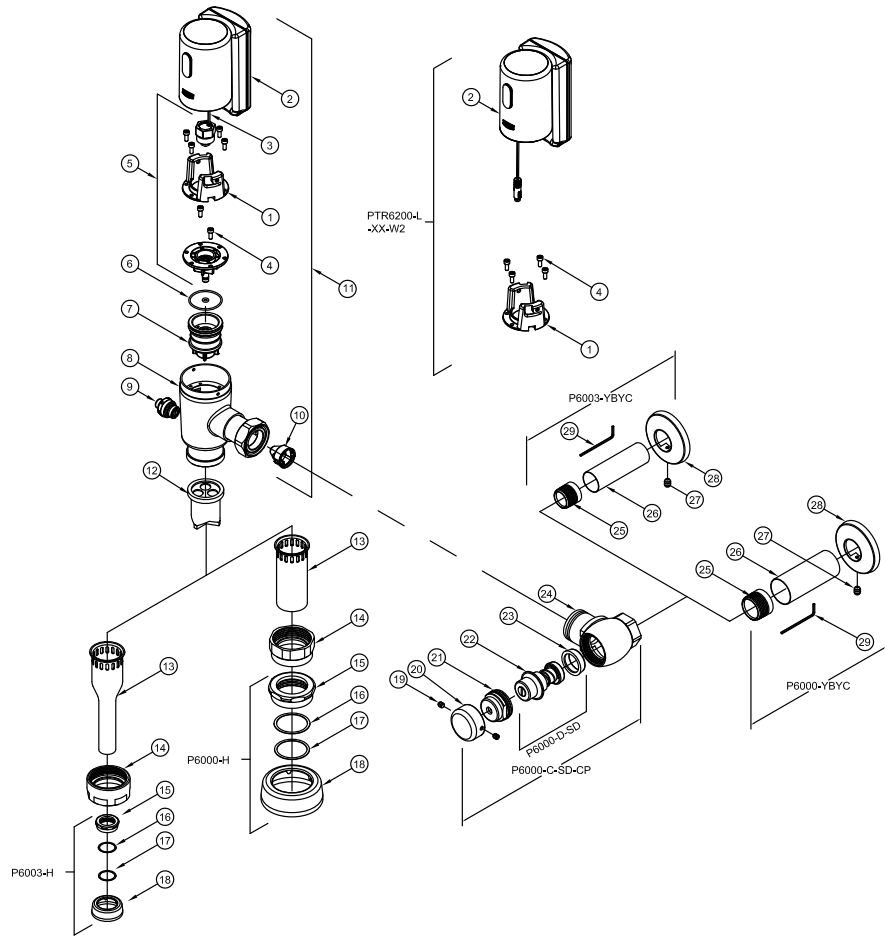

Connected Cap Retrofit Kit, Item 1, 2 & 4	Product No.
Retrofit Kit for Urinal, 0.125 gpf	PTR6200-L-0.125-W2
Retrofit Kit for Urinal, 0.25 gpf	PTR6200-L-0.25-W2
Retrofit Kit for Urinal, 0.5 gpf	PTR6200-L-0.5-W2
Retrofit Kit for Urinal, 1.0 gpf	PTR6200-L-1.0-W2
Retrofit Kit for Water Closet, 1.1 gpf	PTR6200-L-1.1-W2
Retrofit Kit for Water Closet, 1.28 gpf	PTR6200-L-1.28-W2
Retrofit Kit for Water Closet, 1.6 gpf	PTR6200-L-1.6-W2
Retrofit Kit for Water Closet, 1.6/1.1 gpf	PTR6200-L-DF-W2

Flush Connections and Spud Coupling Kits	Product No.
Flush Connection and Spud Coupling, Items 15-18	P6000-H P6003-H
Vacuum Breaker Repair Kit, Items 12	P6000-B-HP P6003-B-HP
Vacuum Breaker Tube, Item 13	P6000-A-CP
Vacuum Breaker Tube Nut, Item 14	P6000-AA-CP

Valve and Components	Product No.
Valve Housing, Items 8 & 9	PTR6200-HSA
Solenoid Replacement Kit for Valves with Metal Caps, Item 5	PTR6200-M
Piston Kit (1.1/1.28/1.6 GPF), Item 7	PTR6200-EC
Piston Kit (0.5/1.0 GPF), Item 7	PTR6203-EU
Piston Kit (0.125/0.25 GPF), Item 7	PTR6203-EU-ULF
Manual Override Button Assy, Item 9	PTR6200-24
Flange O-Ring, Item 6	PTR6200-M-RING
Flange Screws for Valves with Metal Caps, Item 4	PTR6200-M-S-VR
Filter, (1.1/1.28/1.6 gpf), Item 10	P6000-FA
Filter, (1.0/0.5 gpf), Item 10	PTR6203-FA
Filter, (0.25/0.125 gpf), Item 10	PTR6203-FA-LF

Control Stop Repair Kit and Parts	Product No.
Control Stop Repair Kit for 1" and 3/4", Includes Items 19-24	P6000-C-SD-CP
Seal Seat for 1" and 3/4", Includes Item 23	P6000-D42
Sweat Solder Adapter, Includes Item 25	P6000-YBA
Vandal resistant control stop cover Items 19-20	P6000-VC
Sweat solder kit, Items 25-29	P6000-YBYC P6003-YBYC

