

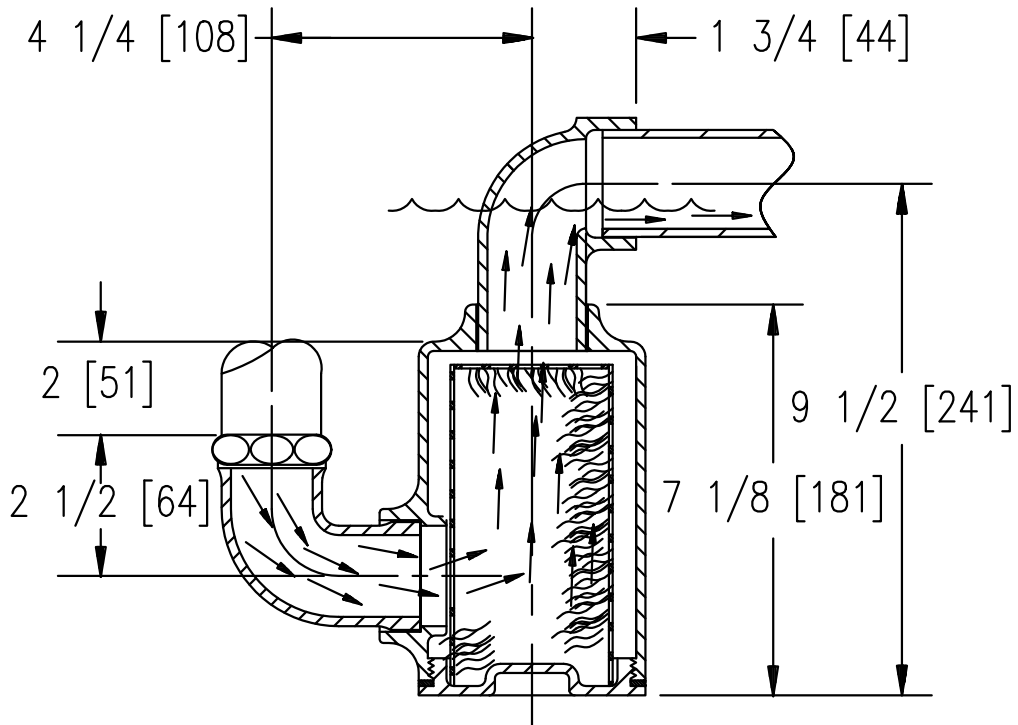

# Z1176 HAIR INTERCEPTOR OPERATION AND MAINTENANCE INSTRUCTIONS

Dimensional Data (inches and [ mm ]) are Subject to Manufacturing Tolerances and Change Without Notice



Inlet/Outlet Inches	Approx. Wt. Lbs.
1 1/2 [38]	8 [4]

## **SIZING**

There are no sizing requirements for this interceptor. All units are made with a 1 1/2[38] standard pipe size inlet and outlet and are capable of handling drainage volumes standard to 1 1/2 pipe.

## **DESIGN**

The Zurn Z-1176 Hair Interceptor is designed to retain the hair from beauty shops, hospitals or wherever hair clogging of the water system is a problem. The removable perforated stainless steel basket retains the accumulating hair before it can pass through to the sanitary sewer system.

## **OPERATION**

The waste water flows from the inlet piping into the perforated basket, passing through the perforations in the basket, into the main body chamber, then exits the main body chamber into the sanitary drain system.

## **MAINTENANCE**

Cleaning should be done on a regular basis, either before or after the basket becomes clogged. Unscrew and remove the bronze, countersunk, flanged cleanout cover, gasket and perforated basket. Remove the accumulated hair and reinstall the basket, gasket and cleanout cover in the body and tighten cover. Efficiency of operation is directly related to the level of maintenance.

**⚠ WARNING:** Cancer and Reproductive Harm - [www.P65Warnings.ca.gov](http://www.P65Warnings.ca.gov)

**⚠ ADVERTENCIA:** Cáncer y daño reproductivo - [www.P65Warnings.ca.gov](http://www.P65Warnings.ca.gov)

**⚠ AVERTISSEMENT:** Cancer et effets néfastes sur la reproduction - [www.P65Warnings.ca.gov](http://www.P65Warnings.ca.gov)