



**Z1456**  
DECK CLEANOUT

SPECIFICATION SHEET

TAG \_\_\_\_\_

Dimensional Data (inches and [ mm ]) are Subject to Manufacturing Tolerances and Change Without Notice

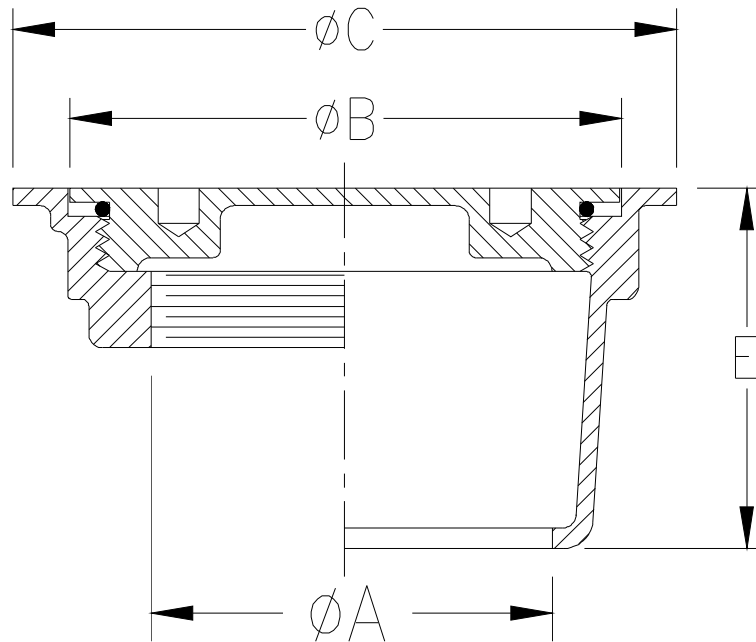

A- Pipe Size	Dimensions in In [mm]				Approx. Wt. Lbs. [kg]
	IC		IP		
	B	C	B	C	
3 [76]	5 [127]	6 [152]	3-1/2 [89]	4-7/8 [124]	4 [2]
4 [102]	6 [152]	7-3/8 [187]	4-1/2 [114]	6 [152]	6 [3]
6 [152]	8 [203]	9-3/8 [238]	7-7/8 [200]	9-3/8 [238]	12 [5]
8 [203]	-	-	9-7/8 [251]	11 [279]	16 [7]

**ENGINEERING SPECIFICATION:**  
ZURNZANB1456  
Deck cleanout, nickel bronze body with scoriated deck plug and O-ring seal.

**OPTIONS** (Check/specify appropriate options)

**PIPE SIZE**

- 3, 4 [76, 102]
- 6 [152]
- 3, 4 [76, 102]
- 6 [152]
- 8 [203]

(Specify size/type) **OUTLET**

- \_\_\_ IC Inside Caulk
- \_\_\_ IC Inside Caulk
- \_\_\_ IP Threaded
- \_\_\_ IP Threaded
- \_\_\_ IP Threaded

**'E' BODY HT. DIM.**

- 3-1/4 [83]
- 3-1/2 [89]
- 1-1/2 [38]
- 1-5/8 [41]
- 2 [51]

**PREFIXES**

\_\_\_ ZANB Nickel Bronze with Polished Scoriated Top\*

**SUFFIXES**

\_\_\_ -SW Extra Spanner Wrench

\* Regularly furnished unless otherwise specified.