



Z415SL

BODY ASSEMBLY W/ "TYPE SL" STRAINER

SPECIFICATION SHEET

TAG _____

Dimensional Data (inches and [mm]) are Subject to Manufacturing Tolerances and Change Without Notice

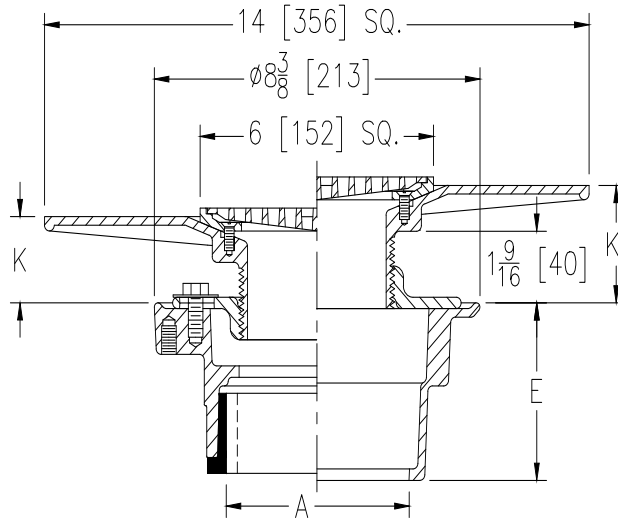

Dimensions in Inches [mm]					Approx. Wt. Lbs. [kg]	Strainer Open Area Sq. In. [cm ²]
A - Pipe Size	K		K'			
	Min.	Max.	Min.	Max.		
2, 3, 4 [51, 76, 102]	1-1/4 [32]	2-5/16 [59]	1-3/4 [44]	3-1/16 [78]	21 [10]	14 [90]

ENGINEERING SPECIFICATION: ZURN ZN415SL

Floor and shower drain, Dura-Coated cast iron body with bottom outlet, combination invertible membrane clamp and adjustable collar with seepage slots and "TYPE SL" polished, nickel bronze square, wide flanged, light-duty strainer.

OPTIONS (Check/specify appropriate options)

PIPE SIZE	(Specify size/type)	OUTLET	'E' BODY HT. DIM.
2, 3, 4 [51, 76, 102]	___ IC	Inside Caulk	4-3/16 [106]
2 [51]	___ IP	Threaded	2-7/16 [62]
3 [76]	___ IP	Threaded	2-3/4 [70]
4 [102]	___ IP	Threaded	2-13/16 [71]
2,3,4 [51,76,102]	___ NH	No-Hub	3-13/16 [98]
2,3,4 [51,76,102]	___ NL	Neo-Loc	3-7/8 [98]

PREFIXES

- ___ ZB D.C.C.I. Body Assembly w/ Polished Bronze Top
- ___ ZN D.C.C.I. Body Assembly w/ Polished Nickel Bronze Top*

SUFFIXES

- | | |
|--|--|
| ___ -AR Acid Resisting Epoxy Coated Cast Iron | ___ -U 1-3 [25-76] High Extension Adapter |
| ___ -CP Chrome-Plated Bronze Top | ___ -V Backwater Valve |
| ___ -G Galvanized Cast Iron | ___ -VP Vandal-Proof Secured Top |
| ___ -P Trap Primer Connection (Specify 1/2 [13] or 3/4 [19]) | ___ -Y Sediment Bucket |
| ___ -PC Protective Cover | ___ -90 90° Threaded Side Outlet Body Assembly (2 [51], 3 [76] Only) |
| ___ -TC Neo-loc Test Cap Gasket (2,3,4 [51,76,102] NL Outlet Only) | |

* Regularly furnished unless otherwise specified.

⚠ WARNING: Cancer and Reproductive Harm - www.P65Warnings.ca.gov

⚠ ADVERTENCIA: Cáncer y daño reproductivo - www.P65Warnings.ca.gov

⚠ AVERTISSEMENT: Cancer et effets néfastes sur la reproduction - www.P65Warnings.ca.gov

Zurn Industries, LLC | Specification Drainage Operation
1801 Pittsburgh Avenue, Erie, PA USA 16502, Ph. 855.663.9876

In Canada | Zurn Industries Limited
7900 Goreway Drive, Unit 10, Brampton, Ontario L6T 5W6, Ph. 877.892.5216

www.zurn.com

Rev. M
Date: 01/02/23
C.N. No. 144898
Patent zurn.com/patents
Prod. | Dwg. No. Z415SL