



Architectural/Engineering Specification:

Polished chrome-plated widespread faucet with adjustable centers from 6" to 20", a rigid or swing spout, slow-closing metering cartridges, and vandal-resistant ADA compliant color-coded handles. Easy adjustable cycle time, preset to 10 seconds. Unit is furnished with a standard water-conserving 1.0 GPM spray outlet, integral shank filters, mounting hardware, and 1/2" NPSM coupling nuts for standard lavatory risers. Requires less than 5 pounds force to activate per ANSI A117.1.

Zurn Lead Free products (-XL) is the line of durable, high quality brass faucets and fixtures that are designed and manufactured to comply with Section 1417 of the Safe Drinking Water Act (SDWA) which mandates the weighted average lead content of no more than 0.25% of the wetted surface.

Product Features:

- Polymer Metering Cartridge Sleeve
- Chrome-plated cast brass widespread body
- Adjustable centers from 6" to 20"
- Color Coded Brass Metering Handle
- Adjustable Cycle Timing

Compliance and Certification:

- Lead Free Compliant
- ADA Compliant

Rough-in/Overview dimensions

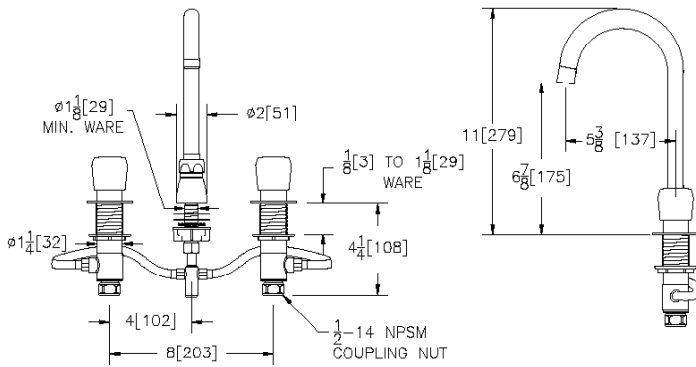

Aerator Options:

	Flow rate GPM [LpM]	Vandal Resistant	Pressure Compression	Outlet Type
-3F	0.5[1.9]	✓	✓	Spray
-7F	1.0[3.8]		✓	Spray
-16F	1.0[3.8]	✓	✓	Spray
-22F	1.0[3.8]	✓		Laminar
-25F	1.0[3.8]	✓	✓	Spray
-28F	1.0[3.8]	✓		Laminar

Suffix Options:

- 140 140° Restricted Swing Gooseneck Spout
- G 1-1/4" [32mm] Grid Strainer Drain
- ICT Inter-connecting Copper Supply Tubes for 8" In-line Centers
- IN Institutional Handle - Tamper-Proof and Vandal-Resistant
- P 1-1/4" [32mm] Pop-up Drain
- RKR ADA Compliant Rocker Handle

Architectural/Engineering Approval

The information contained in this document is subject to change without notice. Please contact Zurn for most up to date information.

