



Model 375DA

2" Reduced Pressure Detector Assembly

Application

Designed for installation on water lines in fire protection systems to protect against both backsiphonage and backpressure of contaminated water into the potable water supply. The Model 375DA shall provide protection where a potential health hazard exists. Incorporates metered by-pass to detect leaks and unauthorized water use. Model 375DA 2 1/2" is supplied with 2" companion flanges.



LEAD FREE



NSF/ANSI/CAN 6

Standards Compliance (applies to 2 1/2" size)

- ASSE® Listed 1047
- AWWA Compliant C550
- UL® Classified
- C-UL® Classified
- FM® Approved
- Approved by the Foundation for Cross Connection Control and Hydraulic Research at the University of Southern California
- Meets the requirements of NSF/ANSI/CAN 61*
*(0.25% MAX. WEIGHTED AVERAGE LEAD CONTENT)

By-Pass Backflow Assembly 3/4" Model 975XLD

Materials

Main valve body	Ductile Iron ASTM A 536 Grade 4
Access covers	Ductile Iron ASTM A 536 Grade 4
Coatings	FDA Approved fusion epoxy finish
Internals	Stainless steel, 300 Series NORYL™
Fasteners	Stainless Steel, 300 Series
Elastomers	EPDM (FDA approved) Buna Nitrile (FDA approved)
Polymers	NORYL™
Springs	Stainless steel, 300 series
Sensing line	Stainless steel, braided hose

Options

(Suffixes can be combined)

- with OS & Y gate valves (standard)
- L - less shut-off valves
- LM - less water meter
- with remote reading meter
- with gpm meter (standard)
- CFM - with cu ft/min meter
- MS - with Integral Relief Valve Monitor Switch
- 509 - with AWWA C509 gate valves

Accessories

- Air gap (Model AG)
- Repair kit (rubber only)
- Thermal expansion tank (Model XT)
- OS & Y Gate valve tamper switch (OSY-40)
- QT-SET Quick Test Fitting Set

Features

Sizes:	2"
Maximum working water pressure	175 PSI
Maximum working water temperature	140°F
Hydrostatic test pressure	350 PSI
End connections (Grooved for steel pipe)	AWWA C606
(Flanged)	ANSI B16.1 Class 125

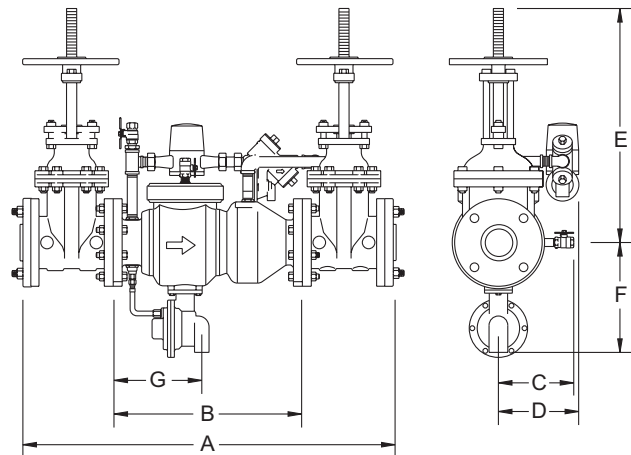

Dimensions & Weights (do not include pkg.)

MODEL 375DA SIZE	DIMENSIONS (approximate)																		WEIGHT	
	A		B LESS GATES VALVES		C		D		E OS&Y GATE (OPEN)		E OS&Y GATE (CLOSED)		F		G		OS&Y GATE VALVES			
	in.	mm	in.	mm	in.	mm	in.	mm	in.	mm	in.	mm	in.	mm	in.	mm	lbs.	kg		
2	50	33 1/2	851	15 7/8	403	7 1/4	184	9	229	16 3/8	416	13 7/8	352	9 1/2	241	8 3/8	213	201	91	

MODEL 375DA 2" (STANDARD & METRIC)

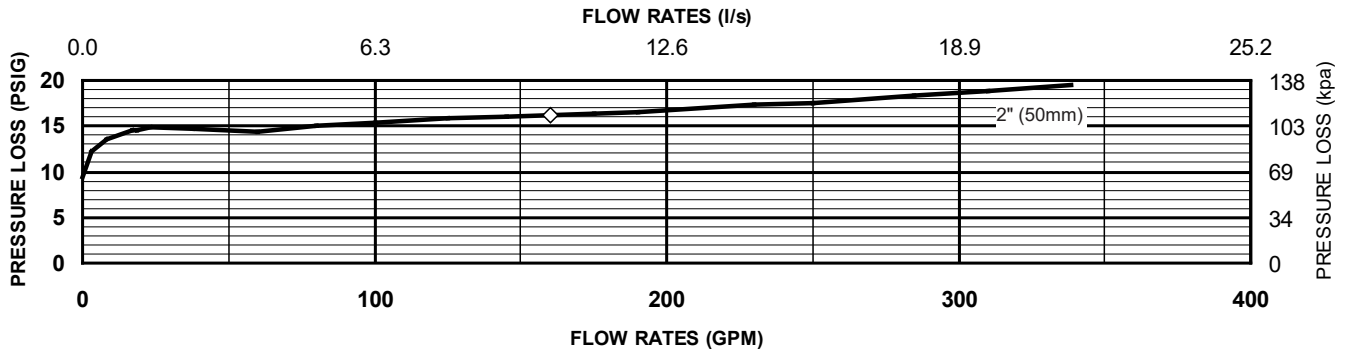

Typical Installation

Local codes shall govern installation requirements. To be installed in accordance with the manufacturers' instructions and the latest edition of the Uniform Plumbing Code. Unless otherwise specified, the assembly shall be mounted at a minimum of 12" (305mm) and a maximum of 30" (762mm) above adequate drains with sufficient side clearance for testing and maintenance. The installation shall be made so that no part of the unit can be submerged.

Capacity thru Schedule 40 Pipe (GPM)				
Pipe size	5 ft/sec	7.5 ft/sec	10 ft/sec	15 ft/sec
2"	52	78	105	167
2 1/2"	75	112	149	224
3"	115	173	230	346
4"	198	298	397	595
6"	450	675	900	1351
8"	780	1169	1559	2339
10"	1229	1843	2458	3687

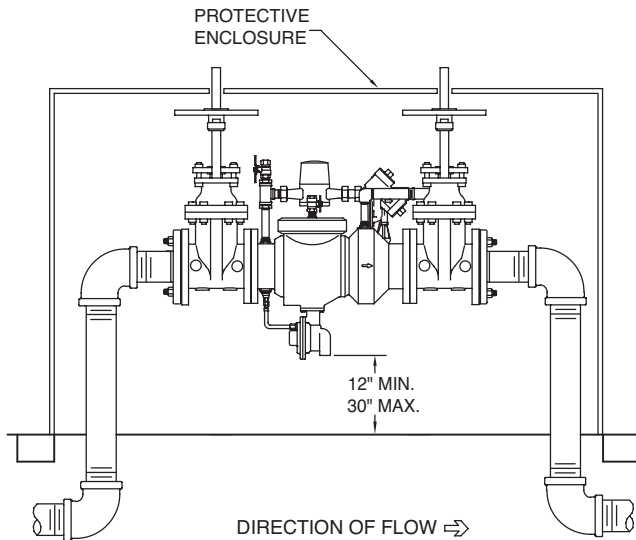

OUTDOOR INSTALLATION

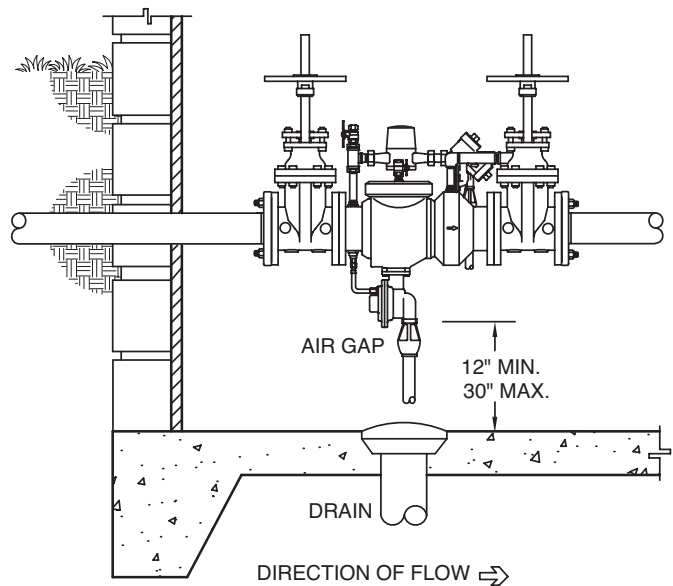

INDOOR INSTALLATION

Specifications

The Reduced Pressure Detector Backflow Prevention Assembly shall be certified to NSF/ANSI/CAN 61, ASSE® Listed 1047, and supplied with full port OS & Y gate valves. The main body and access cover shall be epoxy coated ductile iron (ASTM A 536 Grade 4), the seat ring and check valve shall be NORYL™, the stem shall be stainless steel (ASTM A 276) and the seat disc elastomers shall be EPDM. The checks and the relief valve shall be accessible for maintenance without removing the device from the line. The Reduced Pressure Detector Backflow Prevention Assembly shall be a ZURN WILKINS Model 375DA.