



RFK4X3-400ST

RETROFIT KIT FOR COMPETITOR REPLACEMENT

Application

Designed to adapt ZURN WILKINS 4" 400ST series stainless steel n-pattern backflow preventers to existing 3" risers with 12.5" center-to-center spacing. Ideal for retrofitting existing non-ZURN 3" n-pattern backflow installations. The retrofit kit includes two offset adapters with 4" x 3" flange connections.

Standards Compliance

- Certified to NSF/ANSI 372* by IAPMO R&T
- *(0.25% MAX. WEIGHTED AVERAGE LEAD CONTENT)

Materials

Adapter body Ductile Iron ASTM A 536 Grade 4
Coatings FDA Approved fusion epoxy finish

Accessories

- 3" Bolt kit (3-BK)
- 4" Bolt kit (4-BK)



RFK4X3-400ST
(two adapters included)



LEAD FREE



Features

Sizes: 4" X 3" flanged adapters
Maximum working water pressure
Maximum working water temperature
Flange Connections

175 PSI
140°F
ANSI B16.42
Class 150

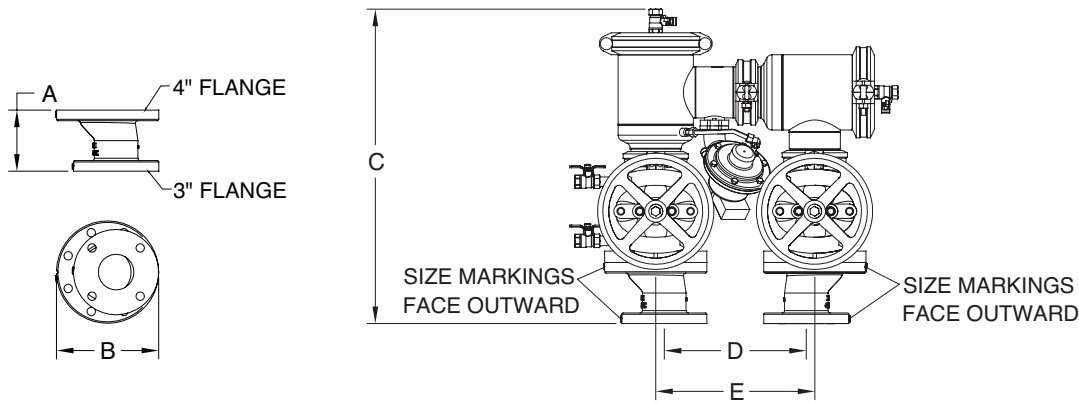

DIMENSIONS & WEIGHTS (do not include pkg.)

DIMENSIONS (approximate)										WEIGHT*	
A		B		C		D		E		lbs.	kg
in.	mm	in.	mm	in.	mm	in.	mm	in.	mm		
5 3/8	137	9	229	27 5/8	702	12 1/2	318	14	356	48	22

*Weight includes two adapters at 24 lbs. (11 kg) each

For enclosure dimensions, visit www.zurn.com

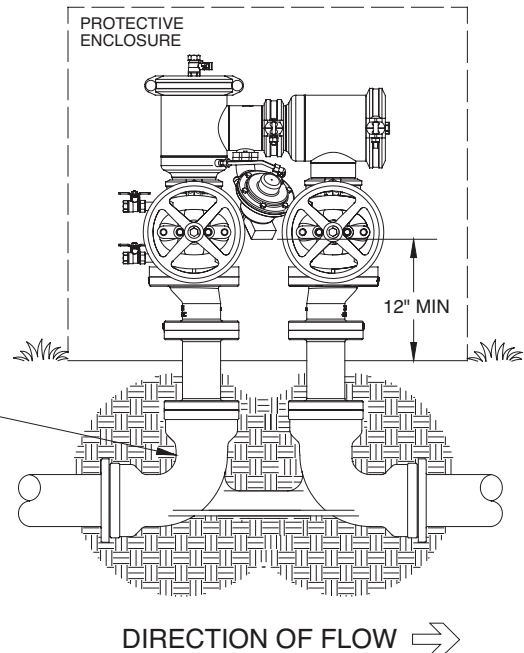

Specifications

The retrofit kit adapters shall meet ANSI B16.42 and ANSI/NSF 372. The adapters shall be FDA approved epoxy resin coated ductile iron (ASTM A536 Grade 4). The retrofit kit shall be a ZURN WILKINS Model RFK4X3-400ST.