



Model F49

Fire Butterfly Valves



Application

Zurn F49 Fire Butterfly Valves provide a slow opening anti-waterhammer adjustment to control waterflow. An integral supervisory tamper switch provides a fire alarm control signal when the valve is moved from the open position.

Materials

Body	ASTM A-536 Nylon-11 Coated
Disc	ASTM A-536 EPDM Encapsulated
Upper & Lower Stems	AISI 420-SS AISI 410-SS
Housing	ASTM A-536
Hand Wheel	ASTM A-536
Flag Indicator	ASTM A-536
Shear Pin	ASTM A-510
Segment Gear	ASTM B-148 or B-584
Housing Gasket	EPDM Grade E
O-Rings (All)	EPDM Grade E

Standards Compliance

- UL[®] Listed
- C-UL[®] Listed
- FM[®] Approved

Features

Maximum Pressure: 300 PSI
 Sizes: 2-1/2", 3", 4", 6", 8", 10", 12"

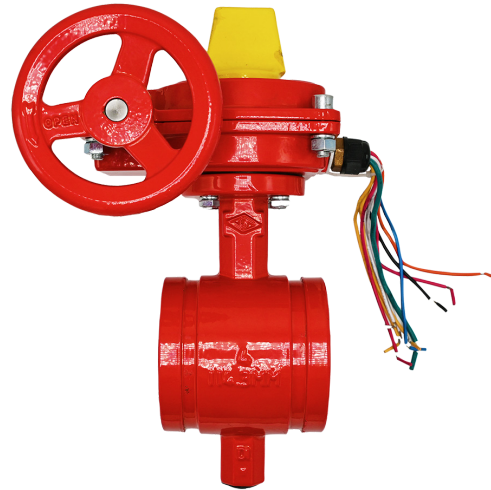

4-F49

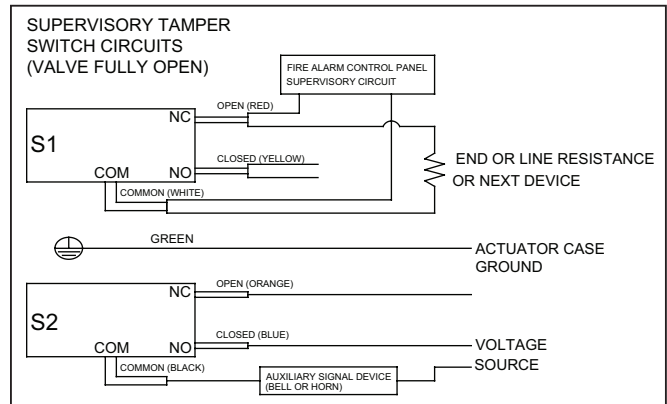
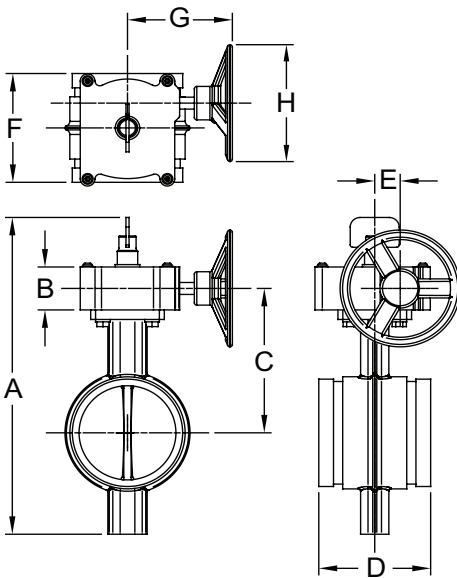

Dimensions & Weights (do not include pkg.)

MODEL	DIMENSIONS (approximate)								Weight (lb.)
	A (in.)	B (in.)	C (in.)	D (in.)	E (in.)	F (in.)	G (in.)	H (in.)	
212-F49	11.63	2.41	5.22	3.82	0.98	5.48	5.00	4.92	11.8
3-F49	12.30	2.41	5.50	3.82	0.98	5.49	5.00	4.92	12.7
4-F49	13.60	2.41	6.25	4.57	0.98	5.75	5.00	4.92	15.7
6-F49	16.08	2.41	7.23	5.83	0.98	6.11	5.49	8.86	28.5
8-F49	18.52	2.41	8.45	5.24	0.98	6.42	7.81	8.86	43.5
10-F49	21.04	2.41	9.71	6.26	2.95	6.85	7.81	8.86	62.80
12-F49	24.09	2.60	11.30	6.50	3.43	7.80	7.97	8.86	91.40