

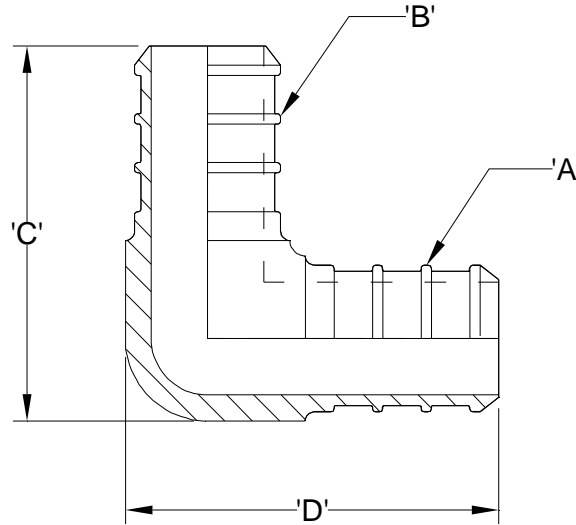

Zurn PEX® XL-Low Lead Brass UL 1821 Listed Barb Elbow - QQE55GFX Specification Sheet

Tag _____

Dimensional Data: Inches and [mm] are subject to manufacturing tolerances and change without notice.
Note: Barb geometry will vary depending upon barb size.



Part Number	Description	'A'	'B'	'C'	'D'
QQE55GFX	1" Barb x 1" Barb Elbow	1" Barb	1" Barb	1.86" [47.2]	1.82" [46.2]

Engineering Specification: Zurn PEX® XL-Low Lead Brass Barb Elbow. The QQE55GFX is used to make sharp 90° bends. Manufactured from EcoBrass®. These fittings, as a system with Zurn PEX® tube, are pressure rated at 160 PSI at 73°F, 130 PSI at 120°F (fire protection rating), 100 PSI at 180°F, and 80 PSI at 200°F. These fittings are listed by NSF as complying with the following standards: NSF/ANSI Standard 14, NSF/ANSI Standard 61 including Annex G, ASTM F877, CSA B137.5, ASTM F1807, and UL 1821.

Accessories

- QCLP5X 1" QuickClamp® Crimp Ring
- QCR5X 1" Copper Crimp Ring

Rev.	Date: 10/8/10	C.N. No. 111815
Dwg. No. 302756	Prod. No. QQE55GFX	