

Architectural/Engineering Specification:

Zurn Connected Faucets transmit data 24/7 to the Zurn plumbSMART™* web portal and mobile app. Proactively monitor your faucet activations and water usage, receive real-time alerts for preset high and low usage parameters, and access system data for trends and predictive maintenance anytime and anywhere.

Zurn AquaSense® Sensor Faucets are ideal for high-use applications where durability and hands-free operation are necessary. ADA compliant, battery powered, polished chrome-plated cast brass sensor faucet with infrared proximity sensor for retrofit and new construction. Unit is furnished with a standard 0.5 GPM aerator, and mounting hardware.

Zurn Lead Free products (-XL) is the line of durable, high quality brass faucets and fixtures that are designed and manufactured to comply with Section 1417 of the Safe Drinking Water Act (SDWA) which mandates the weighted average lead content of no more than 0.25% of the wetted surface.

Product Features:

plumbSMART™ Portal

- Know water consumption
- Track uses per fixture
- Receive real-time alerts
- Manage maintenance tasks
- Receive insights on your data

Sensor Faucet

- Self-sustaining hydropower for 10+ years of operation
- Occupant detection
- Chrome-plated cast brass spout
- In-line filter
- Inlet for a 1/2"[13] ball riser

Technical Specification:

Faucet

- 4 "AA" Batteries (Lithium included)
- 4 Years Battery Life

Connected Endpoint

- 4 "AA" Batteries (Lithium included)
- Mounts under the sink deck
- Communicates wirelessly to Zurn gateway
- Connects to faucet Sensor and electronics module

Zurn Gateway:

- Communicates via Ethernet or LTE
- Works with all Zurn connected devices
- Connects all endpoints up to 1,000 ft radius
- After purchase request your gateway at: zurn.com/plumbsmart-gateway or Call 1-844-987-6737



Aerator Options

	Flowrate gpm [lpm]	Vandal resistant	WaterSense* labeled	Outlet type
-E	1.5 [5.7]	✓	✓	Aerator
-F	0.5 [1.9]	✓		Non-aerated
-J	1.5 [5.7]	✓	✓	Laminar
-K	1.0 [3.8]	✓	✓	Laminar
-L	1.0 [3.8]	✓	✓	Aerator
-N	0.5 [1.9]	✓		Laminar

Suffix Options:

- CP4 Cover Plate 4"[102] Centers
- MV Temperature Mixing Valve

Gateway Options:

(Required & Sold Separately)

- LTE ZGW-LORA-W1-LTE
- Ethernet ZGW-LORA-W1-ETH

Note: plumbSMART™ is free-to-connect to a basic plan with an option to upgrade to a premium plan.

Note: LTE charges will apply to basic plan.

Compliance and Certification:

- ADA Compliant
- ASME A112.18.1/CSA B125.1
- cUPC
- Lead Free Compliant
- Texas Accessibility Standard (TAS)



*This device is WaterSense labeled when used with the appropriate flow rate and certified for residential and private restrooms.

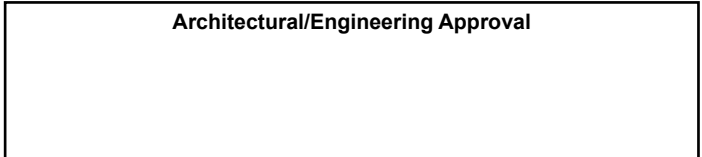

The information contained in this document is subject to change without notice. Please contact Zurn for most up to date information.

How It Works

Integrated sensors continuously monitor faucet activations and water usage. This data is transmitted to the Zurn gateway via LoRa communication. The Zurn gateway passes the data into the Zurn cloud where the data is enriched and presented in the plumbSMART web portal and mobile app. Facilities managers and/or maintenance personnel can view all data and trends in the plumbSMART™ portal and may opt to receive real-time alerts via email, text message and/or push notifications if any of these readings exceed customizable parameters for high hourly or daily usage levels. All notifications and alert parameters are adjustable via the plumbSMART™ portal. A maintenance planning tool and data insights hub are available in plumbSMART. For more information, visit <https://www.zurn.com/innovation-efficiency/plumbSMART>.

To access the plumbSMART™ portal, a Zurn Gateway must be installed within 1,000 feet of the connected product, and connected products must be registered in the Zurn plumbSMART™ portal. A single Zurn Gateway can be used to connect hundreds of Zurn connected plumbing products.

Connecting to the plumbSMART™ Portal

1. Visit www.zurn.com/plumbSMART-connect to save time and money on your installation. You can also call us at 844-987-6737.
2. Provide the serial number and contact name, email address, and basic information about the installation site.
3. We will activate your plumbSMART™ account, set up your enterprise, and give you guidance on how to register each connected product as you install it.
4. We will send a confirmation email with a link, or you can go to plumbsmart.zurn.com to log into your plumbSMART™ account for the first time.
5. Add other users and installers to your plumbSMART™ account.
6. Make sure you and/or your installers have the plumbSMART™ mobile app, which you can download from the iPhone App Store or Google Play.
7. Using the mobile app, scan or enter the serial number to register and locate each connected plumbing product as you install it.
8. Watch the how-to videos in the plumbSMART™ portal's support section if you get stuck, or call us at 844-987-6737 for support.



Rough-in dimensions/Overview dimensions

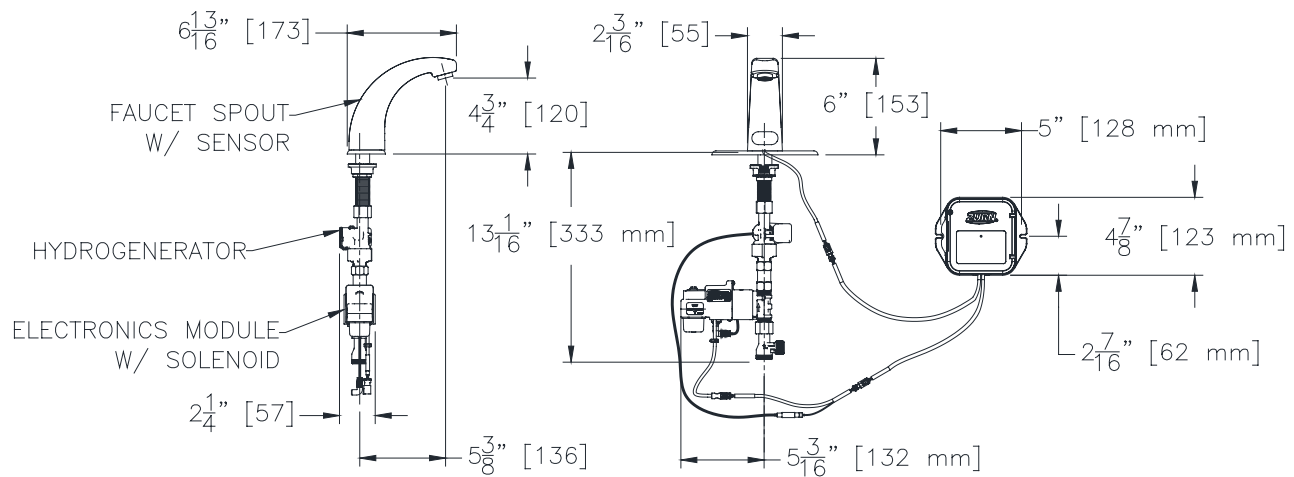

Note: Endpoint must be installed within a 2' [610] radius of faucet.