



# Model P1500XL, P1520XL & P1550XL Pressure Relief Valves

## Application

Ideal where Lead-Free\* valves are required. Designed for installation on cold water service lines as a means of protection against excessive pressure buildup. These devices are for pressure only and should be used in conjunction with other temperature limiting devices. Also suitable for static relief, low capacity pump relief, passive solar, thermal expansion control and other similar uses in commercial and industrial applications.

## Standards Compliance

- Certified to NSF/ANSI 372\* by IAPMO R&T  
\*(0.25% MAX. WEIGHTED AVERAGE LEAD CONTENT)

## Materials

Main valve body	Low Lead Cast Bronze
Access covers	Brass
Internals	Stainless Steel
	Brass
Elastomers	Silicone
	Buna Nitrile
Springs	Stainless steel

## Features

Sizes: 1/2", 3/4"

Maximum working water pressure	175 PSI
Maximum working water temperature	210°F
Hydrostatic test pressure	175 PSI
Threaded connections (MNPT x FNPT)	ANSI B1.20.1
(Available 1/2" FNPT outlet only)	



P1500XL



P1520XL



P1550XL



## Options

- P1500XL - calibrated adjustments from 25 to 175 psi
- P1520XL - with 50, 75, 100 and 125 psi relief settings
- P1550XL - with 75 psi and 125 psi relief setting (imported)

## Accessories

- Water Hammer Arrester (Model 1260XL)
- Water Pressure Reducing Valve (Model NR3XL)
- Vacuum Relief Valve (Model VR10XL)

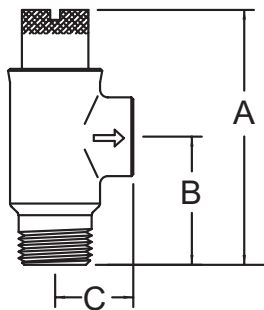

P1500XL

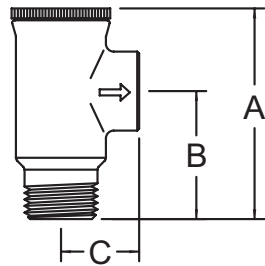

P1520XL

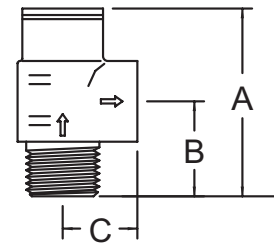

P1550XL

## Dimensions & Weights (do not include pkg.)

MODEL	SIZE		PRESSURE RANGE		DIMENSIONS (approximate)						WEIGHT	
					A		B		C			
	in.	mm	psi	kpa	in.	mm	in.	mm	in.	mm	lbs.	kg.
P1500XL	1/2	15	25 to 175	170 to 1200	3 3/8	86	1 1/4	32	1	25	1/2	0.20
P1500XL	3/4	20	25 to 175	170 to 1200	3 3/8	86	1 1/4	32	1	25	1/2	0.20
P1520XL	1/2	15	50 to 125	340 to 860	2 1/2	64	1 1/4	32	1	25	1/2	0.20
P1520XL	3/4	20	50 to 125	340 to 860	2 1/2	64	1 1/4	32	1	25	1/2	0.20
P1550XL	1/2	15	75 & 125	515 & 860	2 5/16	59	1 1/4	32	7/8	22	1/2	0.20
P1550XL	3/4	20	75 & 125	515 & 860	2 5/16	59	1 1/4	32	7/8	22	1/2	0.20

**Typical Installation**

Local codes shall govern installation requirements. Unless otherwise specified, the assembly shall be mounted in accordance with the manufacturers' instructions and the latest edition of the Uniform Plumbing Code. Assembly shall be installed with adequate drain and sufficient side clearance for testing and maintenance. The installation shall be made so that no part of the unit can be submerged or where relief valve discharge could cause damage.

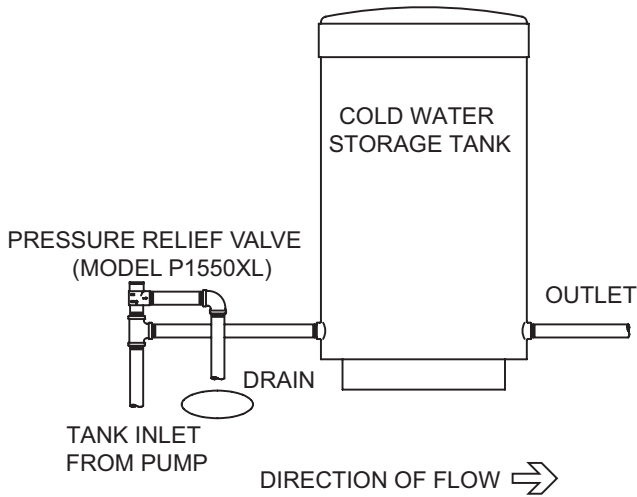

**TYPICAL INSTALLATION**  
(PUMP PRESSURE RELIEF)

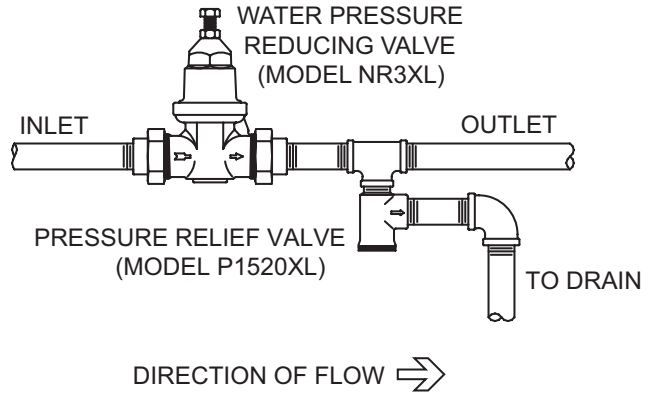

**TYPICAL INSTALLATION**  
(THERMAL EXPANSION CONTROL)

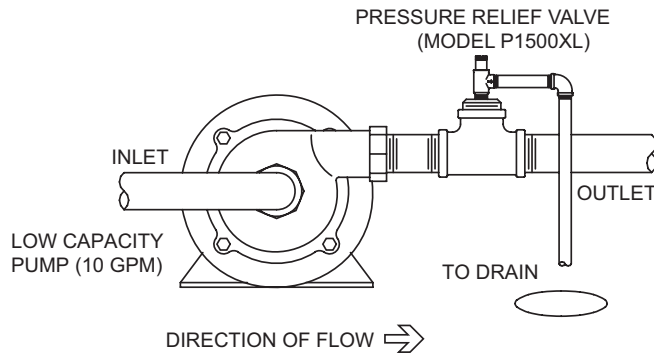

**TYPICAL INSTALLATION**  
(PUMP PRESSURE RELIEF)

**Specifications**

The Pressure Relief Valve shall be certified to NSF/ANSI 372, consisting of a low lead bronze body and an internally-loaded "poppet" type pressure sensing member. The main body shall have a male pipe thread on the inlet and a female pipe thread on the outlet. The Pressure Relief Valve shall be a ZURN WILKINS Model P1500XL, P1520XL or P1550XL.