



Z1072

ZShield™ BARRIER TRAP SEAL DEVICE FOR FLOOR DRAINS

Design and Dimensional Data (inches and [mm]) are Subject to Manufacturing Tolerances and Change Without Notice

Z1072-4 Illustrated

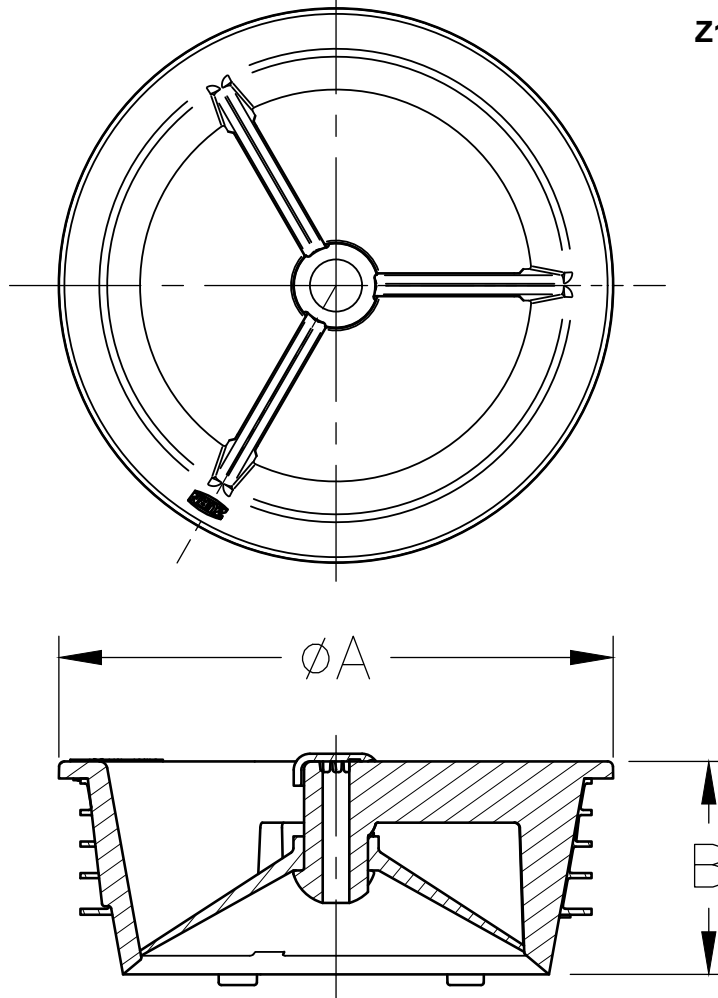

Product Designation	Dimensions in Inches [mm]		ASSE 1072 Required Flow Rate G.P.M [L.P.M]
	A	B	
-2	2.20 [56]	1.22 [31]	12 [45.4]
-3	3.25 [83]	1.25 [32]	34 [128.7]
-3.5	3.53 [90]	1.30 [33]	52 [196.8]
-4	4.13 [105]	1.30 [33]	73 [276.4]

ENGINEERING SPECIFICATION: ZURN Z1072

ZShield™ Barrier trap seal device for use with floor drains to minimize trap evaporation. Product is comprised of an ABS rigid structure, silicone gasket and seal for 2" [51 mm], 3" [76 mm], 3-1/2" [89 mm], and 4" [102 mm] sizes. Device is engineered to comply with the performance requirements of ASSE 1072 standard and is third party listed with IAPMO (UPC), ICC (ICC cES PMG) and ASSE.

OPTIONS (Check/specify appropriate options)

- ___ -2 Barrier Trap Seal for 2 [51] Pipe/Outlet
- ___ -3 Barrier Trap Seal for 3 [76] Pipe/Outlet
- ___ -3.5 Barrier Trap Seal for 3-1/2 [89] Pipe/Outlet
- ___ -4 Barrier Trap Seal for 4 [102] Pipe/Outlet

* Regularly furnished unless otherwise specified

⚠ WARNING: Cancer and Reproductive Harm - www.P65Warnings.ca.gov

⚠ ADVERTENCIA: Cáncer y daño reproductivo - www.P65Warnings.ca.gov

⚠ AVERTISSEMENT: Cancer et effets néfastes sur la reproduction - www.P65Warnings.ca.gov

Zurn Industries, LLC | Specification Drainage Operation
1801 Pittsburgh Avenue, Erie, PA 16502, Ph. 855.663.9876

In Canada | Zurn Industries Limited
7900 Goreway Drive, Unit 10, Brampton, Ontario L6T 5W6, Ph. 877.892.5216

www.zurn.com

Rev.	D
Date:	01/10/23
C.N. No.	144896
Patent	zurn.com/patents
Prod. Dwg. No.	Z1072