

Design and Dimensional Data (inches and [ mm ]) are Subject to Manufacturing Tolerances and Change Without Notice

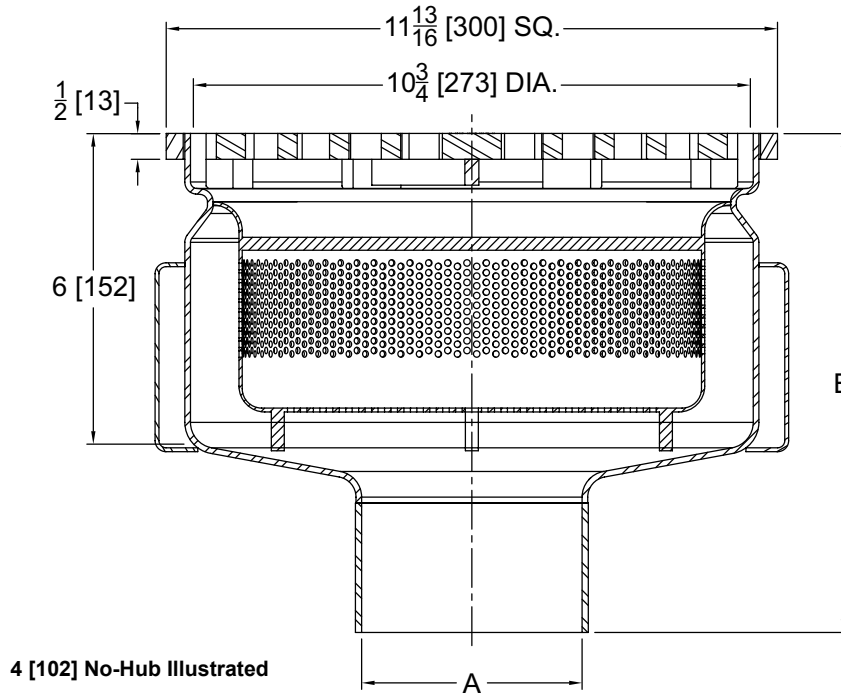

**ENGINEERING SPECIFICATION:** ZURN Z1805-12S

12 [305] Square x 6 [152] Deep, 12 gauge, type 304 stainless steel industrial sanitary drain featuring 100% spun drain body construction, sloped bottom design and minimum continuous welds. Provided with perforated removable sediment bucket with lift handle, extra heavy-duty slotted grate, pre-pour stabilizing anchor tabs, and smooth bead blasted finish. Drain meets US FDA standards for corrosion resistance.

**OPTIONS** (Check/specify appropriate options)

**PIPE SIZE**

	(Specify size/type)	OUTLET	E BODY HT. DIM.
3[76]	_____	NH No-Hub (sch. 10)	9 3/4 [247.7]
4[102]	_____	NH No-Hub (sch. 10)	9 21/32 [245.3]
6[152]	_____	NH No-Hub (sch. 10)	9 7/16 [239.7]
3[76]	_____	BW Butt-Weld (sch. 40)	9 3/4 [247.7]
4[102]	_____	BW Butt-Weld (sch. 40)	9 21/32 [245.3]
6[152]	_____	BW Butt-Weld (sch. 40)	9 7/16 [239.7]
3[76]	_____	IP Threaded	9 1/16 [230.2]
4[102]	_____	IP Threaded	9 [228.6]
6[152]	_____	IP Threaded	8 3/4 [222.3]

**PREFIXES**

_____ Z1805-12S*	Type 304 (CF8) Stainless Steel Drain	_____ ZM1805-12S	Type 316 (CF8M) Stainless Steel Drain
------------------	--------------------------------------	------------------	---------------------------------------

**GRATES**

		OPEN AREA
_____ -H3	Special Duty Perimeter Gap Grate	12.8 in <sup>2</sup> [82.4 cm <sup>2</sup> ]
_____ -H5	Extra Heavy Duty Slotted Grate*	42.8 in <sup>2</sup> [276.0 cm <sup>2</sup> ]
_____ -H9	Medium Duty Perforated Grate	25.6 in <sup>2</sup> [165.2 cm <sup>2</sup> ]

**SUFFIXES**

_____ -K	Anchor Flange
_____ -KC	Anchor Flange with Seepage Holes and Clamp Collar
_____ -MG	EZ Lock Magnetic System With Secured Secondary Strainer
_____ -P	3/4 [19] Trap Primer Connection
_____ -VP	Vandal Proof Secured Top

\* Regularly furnished unless otherwise specified

Products bearing the NSF mark are certified and listed by NSF International. For more information, visit [www.nsf.org](http://www.nsf.org).

**⚠ WARNING:** Cancer and Reproductive Harm - [www.P65Warnings.ca.gov](http://www.P65Warnings.ca.gov)

**⚠ ADVERTENCIA:** Cáncer y daño reproductivo - [www.P65Warnings.ca.gov](http://www.P65Warnings.ca.gov)

**⚠ AVERTISSEMENT:** Cancer et effets néfastes sur la reproduction - [www.P65Warnings.ca.gov](http://www.P65Warnings.ca.gov)