



# Z1832

6" [152] DIAMETER ROUND INDUSTRIAL AREA DRAIN

SPECIFICATION SHEET

TAG \_\_\_\_\_

Design and Dimensional Data (inches and [ mm ]) are Subject to Manufacturing Tolerances and Change Without Notice

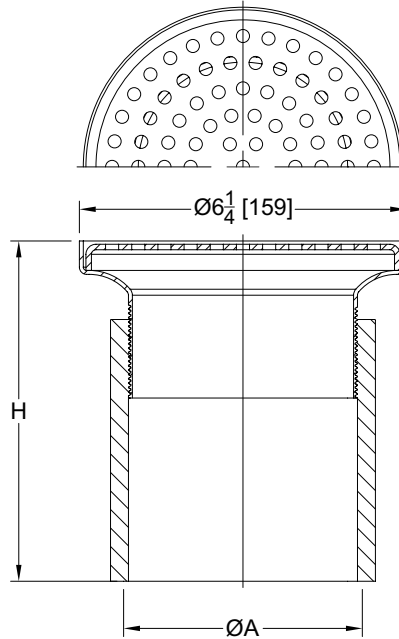

### ENGINEERING SPECIFICATION: Z1832

6-1/4 [159] Diameter, 12 gauge, type 304 stainless steel, adjustable round drain features light-duty perforated grates, and bead blasted finish. Drain meets U.S. FDA standards for corrosion resistance.

**OPTIONS** (Check/specify appropriate options)

**PIPE SIZE (ØA)**

2, 3, 4 [51, 76, 102]

**OUTLET (specify size)**

\_\_\_\_ NH No-Hub

Dimensions in In. [mm]			Approx. Wt. Lbs. [kg]	Strainer Open Area Sq.In. [cm <sup>2</sup> ]
'A' Pipe Size	H			
	Min.	Max.		
2 [51]	6-3/16 [157]	7-3/16 [183]	6 [3]	6-3/4 [44]
3 [76]	4-1/2 [114]	6-1/2 [165]		
4 [102]	4-5/16 [110]	6-1/16 [154]		

### PREFIXES

- \_\_\_\_ Z Type 304 (CF8) Stainless Steel\*
- \_\_\_\_ ZM Type 316 (CF8M) Stainless Steel

### SUFFIXES

- \_\_\_\_ -A Adjustable Threaded Outlet
- \_\_\_\_ -KC Anchor Flange w/ Seepage Holes and Clamp Collar
- \_\_\_\_ -P 1/2 [13] Trap Primer Connection
- \_\_\_\_ -Y Sediment Basket

\* Regularly furnished unless otherwise specified

**⚠ WARNING:** Cancer and Reproductive Harm - [www.P65Warnings.ca.gov](http://www.P65Warnings.ca.gov)

**⚠ ADVERTENCIA:** Cáncer y daño reproductivo - [www.P65Warnings.ca.gov](http://www.P65Warnings.ca.gov)

**⚠ AVERTISSEMENT:** Cancer et effets néfastes sur la reproduction - [www.P65Warnings.ca.gov](http://www.P65Warnings.ca.gov)

Zurn Industries, LLC | Specification Drainage Operation  
1801 Pittsburgh Avenue, Erie, PA 16502, Ph. 855.663.9876

In Canada | Zurn Industries Limited  
7900 Goreway Drive, Unit 10, Brampton, Ontario L6T 5W6, Ph. 877.892.5216

[www.zurn.com](http://www.zurn.com)

Rev.	C
Date:	11/01/2021
C.N. No.	144127
Prod.   Dwg. No.	Z1832