



Z1901-RL

12 x 12 x 8 [305 x 305 x 203] REPLACEMENT FLOOR SINK LINER

SPECIFICATION SHEET

TAG _____

Design and Dimensional Data (inches and [mm]) are Subject to Manufacturing Tolerances and Change Without Notice

ENGINEERING SPECIFICATION: ZURN Z1901-RL
12 x 12 x 8 [305 x 305 x 203] deep, 18 gage, all type 304 (CF8) fabricated stainless steel replacement floor sink liner, with internal pipe gasket seal, light-duty slotted, loose set grate and perforated removable dome strainer.

Approx. Wt. Lbs. [kg]	Grate Open Area Sq. In. [cm2]
7 [3]	21.7 [140]

OPTIONS (Check/specify appropriate options)

PIPE SIZE (ØA)
2-3-4 [51-76-102]

PREFIXES
___ Z All Type 304 (CF8) Fabricated Stainless Steel*

SUFFIXES
___ -1 Less Grate
___ -2 1/2 Grate
___ -3 3/4 Grate
___ -Y Sediment Bucket

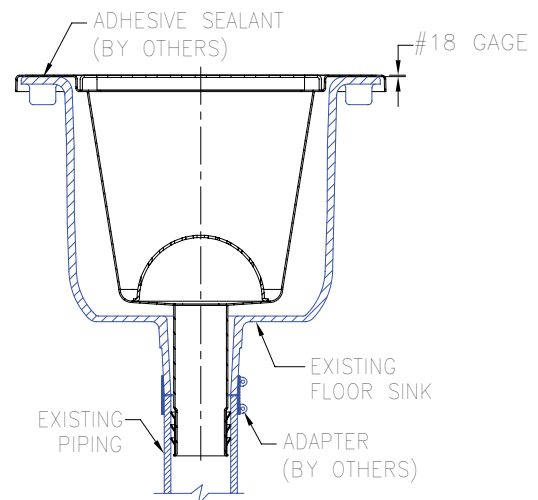
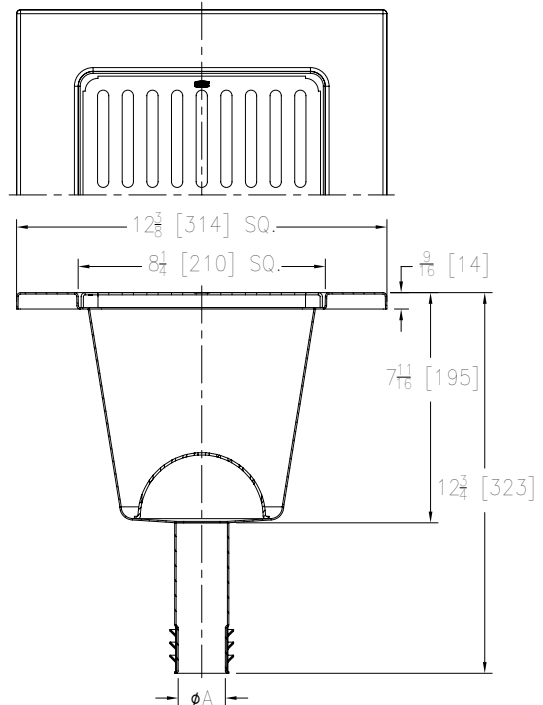

* Regularly furnished unless otherwise specified

⚠ WARNING: Cancer and Reproductive Harm - www.P65Warnings.ca.gov
⚠ ADVERTENCIA: Cáncer y daño reproductivo - www.P65Warnings.ca.gov
⚠ AVERTISSEMENT: Cancer et effets néfastes sur la reproduction - www.P65Warnings.ca.gov

Zurn Industries, LLC | Specification Drainage Operation
1801 Pittsburgh Avenue, Erie, PA 16502, Ph. 855.663.9876

In Canada | Zurn Industries Limited
7900 Goreway Drive, Unit 10, Brampton, Ontario L6T 5W6, Ph. 877.892.5216

www.zurn.com

Rev. C
Date: 01/11/23
C.N. No. 144899
Patent zurn.com/patents
Prod. | Dwg. No. Z1901-RL