



Z415SC

BODY ASSEMBLY W/ "TYPE SC" STRAINER

SPECIFICATION SHEET

TAG _____

Dimensional Data (inches and [mm]) are Subject to Manufacturing Tolerances and Change Without Notice

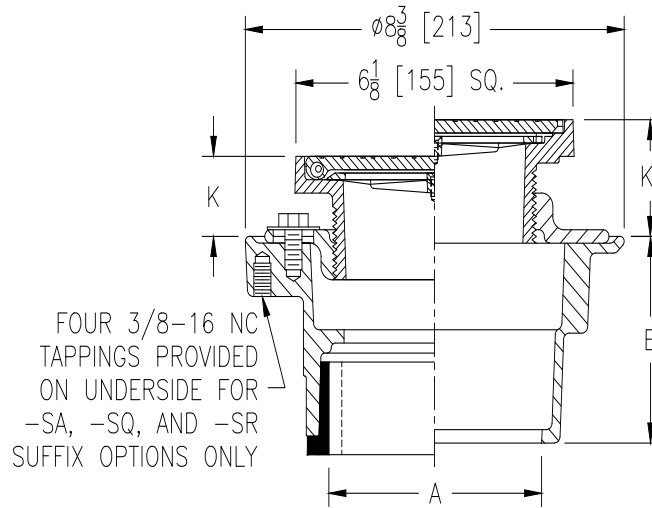

Dimensions in Inches [mm]					Approx. Wt. Lbs. [kg]
A - Pipe Size	K		K'		
	Min.	Max.	Min.	Max.	
2, 3, 4 [51, 76, 102]	1-3/16 [30]	1-15/16 [49]	1-3/4 [44]	2-7/8 [73]	16 [7]

ENGINEERING SPECIFICATION: ZURN ZN415SC

Floor and shower drain, Dura-Coated cast iron body with bottom outlet, combination invertible membrane clamp, adjustable collar with seepage slots and "TYPE SC" polished nickel bronze strainer with flashing clamp device and adjustable strainer top with solid scoriated hinged, light-duty cover.

OPTIONS (Check/specify appropriate options)

PIPE SIZE	(Specify size/type)	OUTLET	'E' BODY HT. DIM.
2,3,4 [51,76,102]	___ NH	No-Hub	3-13/16 [97]
2,3,4 [51,76,102]	___ NL	Neo-Loc	3-7/8 [98]

PREFIXES

- ___ ZB D.C.C.I. Body Assembly w/ Polished Bronze Top
- ___ ZN D.C.C.I. Body Assembly w/ Polished Nickel Bronze Top*

SUFFIXES

- | | |
|--|---|
| ___ -AR Acid Resisting Epoxy Coated Cast Iron | ___ -TS Top Secured with Slotted Screw |
| ___ -CP Chrome-Plated BronzeTop | ___ -TC Neo-loc Test Cap Gasket |
| ___ -G Galvanized Cast Iron | (2,3,4 [51,76,102] NL Bottom Outlet Only) |
| ___ -GC Gasketed Cover | ___ -U 1-3 [25-76] High Extension Adapter |
| ___ -LR Lift Ring | ___ -V Backwater Valve (Cannot be Configured W/ -Y) |
| ___ -P Trap Primer Connection (Specify 1/2 [13] or 3/4 [19]) | ___ -VP Vandal-Proof Secured Top |
| ___ -SA Stabilizer Assembly (See Z1035) | ___ -Y Sediment Bucket(Cannot be Configured W/ -V) |
| ___ -SQ Stabilizer Q-Deck (See Z1035-Q) | |
| ___ -SR Stabilizer Ring | |

* Regularly furnished unless otherwise specified.

⚠ WARNING: Cancer and Reproductive Harm - www.P65Warnings.ca.gov

⚠ ADVERTENCIA: Cáncer y daño reproductivo - www.P65Warnings.ca.gov

⚠ AVERTISSEMENT: Cancer et effets néfastes sur la reproduction - www.P65Warnings.ca.gov

Zurn Industries, LLC | Specification Drainage Operation
1801 Pittsburgh Avenue, Erie, PA USA 16502, Ph. 855.663.9876

In Canada | Zurn Industries Limited
7900 Goreway Drive, Unit 10, Brampton, Ontario L6T 5W6, Ph. 877.892.5216

www.zurn.com

Rev. N
Date: 01/05/23
C.N. No. 144898
Patent zurn.com/patents
Prod. | Dwg. No. Z415SC