

ZTR6201-WS1

1.0 gpf Sensor Operated Urinal Flush Valve

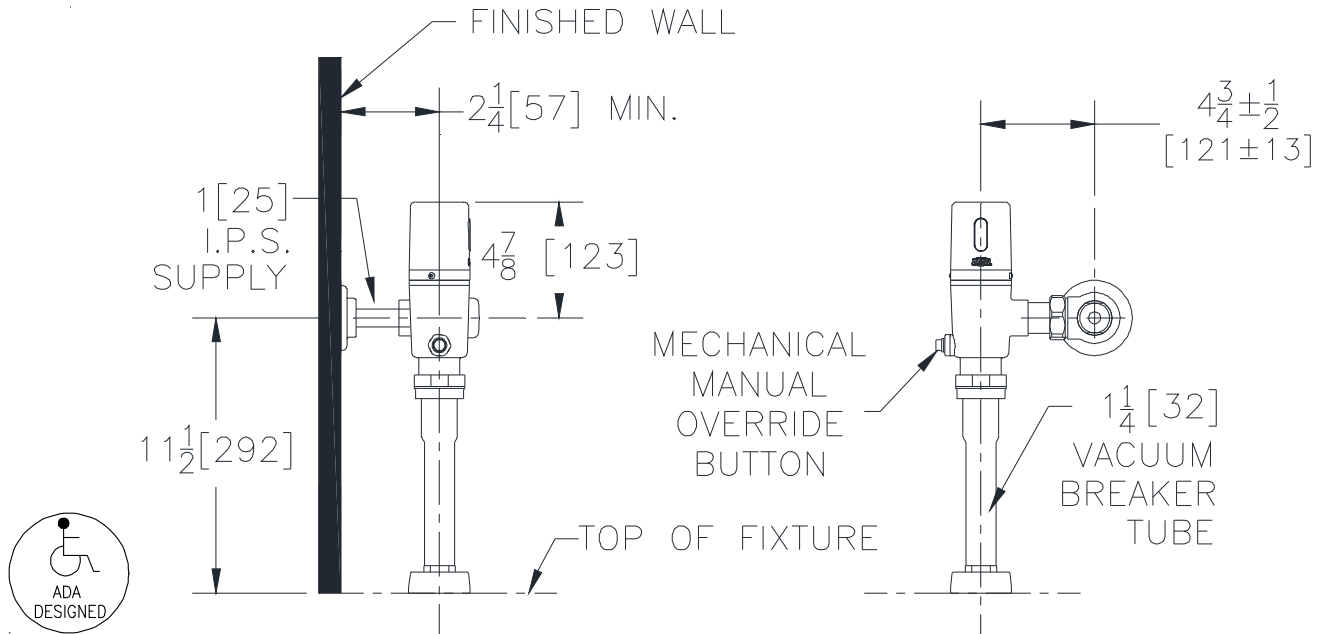

Accessories

- LL 10 Year Long Life Battery
- YJ Split Ring Pipe Support
- YK Solid Ring Pipe Support
- YO Bumper on Angle Stop
- _____ Other

NOTE: Performance guaranteed with Zurn EcoVantage® fixtures. Please consult Zurn Technical Services at 1-800-997-3876 to discuss the paired performance of this valve with other manufacturers fixtures.

Architectural/Engineering Approval

ENGINEERING SPECIFICATIONS

Exposed chrome plated flushometer valve with a polished exterior.

- Filtered Piston Kit
 - Chloramine resistant
- Proprietary DR resistant low lead brass alloy
- Actuator
 - Sensor powered by 4 "AA" batteries
 - 3 year battery life on 48,000 activations per year
- Mechanical Manual Override Button
- Control Stop
 - Internal siphon-guard protection
 - Vandal resistant stop cap
 - Sweat solder kit
 - Cast wall flange with set screw
- Vacuum Breaker
 - High back pressure
 - One piece hex coupling nut
- Internal seals
 - Chloramine resistant
- Adjustable tailpiece
- Spud coupling and flange for top spud connection

ZURN INDUSTRIES, LLC. ♦ COMMERCIAL BRASS OPERATION
 5900 ELWIN BUCHANAN DRIVE ♦ SANFORD NC 27330
 PHONE: 1-800-997-3876 ♦ FAX: 919-775-3541
 WWW.ZURN.COM
 IN CANADA: ZURN INDUSTRIES LIMITED
 3544 NASHUA DRIVE ♦ MISSISSAUGA, ONTARIO L4V1L2
 PHONE: 905-405-8272 FAX: 905-405-1292

The information contained in this document is subject to change without notice.
 Please contact Zurn for most up to date information.