

Model 475ST, 475STR, 475STDA & 475STDAR

Reduced Pressure Principle Assembly (Size, 8" & 10") **LEAD-FREE***
 Reduced Pressure Detector Assembly (Size, 8" & 10")



*This product contains a weighted average lead content less than 0.25% for wetted surfaces.

(Patent No. 5,913,331)

□ Installation □ Testing □ Maintenance Instructions

INSTALLATION INSTRUCTIONS

CAUTION: Installation of Backflow Preventers must be performed by qualified, licensed personnel. The installer should be sure the proper device has been selected for the particular installation. Faulty installation could result in an improperly functioning device.

ZURN WILKINS Model 475ST Series Reduced Pressure Principle assemblies are for use on potable water lines where a health hazard exists in the event of a backflow situation.

Damage to the device could result wherever water hammer and/or water thermal expansion could create excessive line pressure. Where this could occur, shock arrestors, check valves and/or pressure relief valves should be installed downstream of the device.

If installation is in a pit or vault, the Backflow Preventer must never be submerged in water because this could cause a cross-connection. Make sure that the pit or vault always remains dry by providing ample drainage. (Consult local codes.)

1. Before installing a Model 475ST Series Backflow Preventer, flush the line thoroughly to remove all debris, chips and other foreign matter. If required, a strainer should be placed upstream of the Backflow Preventer. **CAUTION: Do not use a strainer in seldom used emergency waterlines such as fire lines.**
2. Provide adequate space around the installed unit so that the test cocks will be accessible for testing and servicing.
3. Install valve at least 6 inches (12 inches for indoor installation) above surrounding flood level.
4. Always consult local codes for installation methods, approvals and guidance.

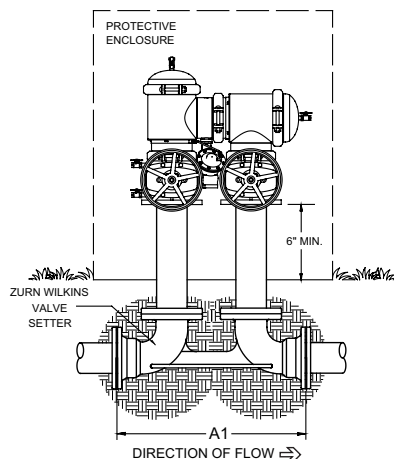

TYPICAL HORIZONTAL ORIENTATION

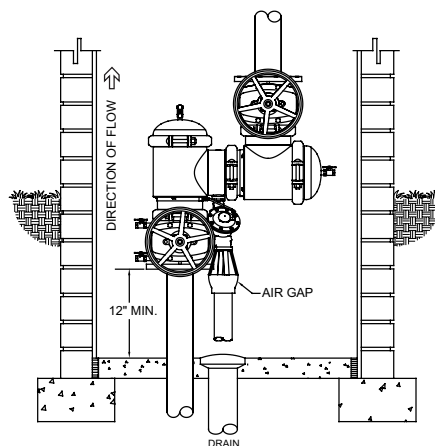

TYPICAL VERTICAL ORIENTATION

OUTDOOR INSTALLATION

The Model 475ST Series Backflow Preventer may be installed outdoors only if the device is protected against freezing conditions. Exposure to freezing conditions will result in improper function or damage to the device. The installation location must be kept above 32°F. All the basic installation instructions apply.

INDOOR INSTALLATION

Indoor installation is preferred in areas that are subject to freezing conditions. All the basic installation instructions apply to such installations. **CAUTION: An adequately sized drain is required to prevent possible water damage due to relief valve discharge.**

PLACING THE MODEL 475ST IN SERVICE

1. Start with both shut-off valves closed. Slowly open the inlet shut-off valve until the Backflow Preventer is completely pressurized. A brief discharge from the relief valve may occur while the device is pressurizing. The discharge should cease by the time the shut-off valve is fully open. If the discharge does not stop, refer to "MAINTENANCE INSTRUCTIONS" for repair procedures.
2. After the device has been pressurized, vent all trapped air by slightly opening each of the four test cocks.
3. Slowly open the downstream shut-off valve. The Model 475ST Series Reduced Pressure Principle Backflow Preventer is now in service.
4. If spitting or intermittent discharges from the relief valve are noted, it could be a result of pressure fluctuation and/or a water hammer condition in the system. If such conditions exist, install water pressure reducing valves or water hammer shock arrestors in compliance with industry standards as needed.
5. After the Model 475ST has been properly installed, test the device (see "TEST PROCEDURES"). If the device fails the test, remove the first and second check valves and thoroughly flush the device. If the relief valve fails to operate properly, inspect the sensing passage for clogging (see "MAINTENANCE INSTRUCTIONS"). Clean rubber seals of all debris and place unit back in service.

VERTICAL INSTALLATION

Vertical Installation is acceptable in applications where inlet and outlet piping are flowing vertically upwards. All the basic installation instructions apply to such installations. Consult factory for approval status.

⚠ **WARNING:** Cancer and Reproductive Harm - www.P65Warnings.ca.gov
 ⚠ **ADVERTENCIA:** Cáncer y daño reproductivo - www.P65Warnings.ca.gov
 ⚠ **AVERTISSEMENT:** Cancer et néfastes sur la reproduction - www.P65Warnings.ca.gov



Testing Procedures

MODEL 475ST REDUCED PRESSURE ASSEMBLY

Equipment Required: Differential pressure gauge test kit.

TEST NO. 1 - RELIEF VALVE OPENING POINT

REQUIREMENT:

The differential pressure relief valve must operate to maintain the zone between the two check valves at least 2 psi less than the supply pressure.

PROCEDURE:

1. Flush water through test cocks #1, #2 (open #2 slowly), #3 and #4 by opening and closing each test cock one at a time, to eliminate foreign material.
2. Install appropriate fittings to test cocks. Attach hose from the high side of the differential pressure gauge to the #2 test cock then attach hose from the low side of the gauge to the #3 test cock. Open test cock #3 slowly and then bleed all air from the hose and gauge by opening the low side bleed needle valve.
3. Maintain the low side bleed needle valve in the open position while test cock #2 is opened slowly. Open the high side bleed needle valve to bleed all air from the hose and gauge. Close the high side bleed needle valve, then close the low side bleed needle valve after the gauge reading has reached the upper end of the scale.
4. Close the #2 shut-off valve. If the gauge reading drops to the low end of the gauge scale and the differential pressure relief valve discharges continuously, then the #1 check valve is leaking. If this occurs, Tests #1, #2 and #3 cannot be completed (See USC Maintenance Guide). However, should the gauge reading remain above the differential pressure relief valve opening point, then observe the gauge reading. This is the apparent pressure drop across the #1 check valve.
5. Open the high side control needle valve approximately one turn, and then open the low side control needle valve no more than 1/4 turn to by-pass water from the #2 test cock to the #3 test cock. Observe the differential pressure reading as it slowly drops to the relief valve opening point. Record this opening point value when the first discharge of water is detected. Close the low side needle valve.

TEST NO. 2 - TIGHTNESS OF #2 CHECK VALVE

REQUIREMENT:

The #2 check valve shall be tight against backpressure.

PROCEDURE:

1. Maintain the #2 shut-off valve in the closed position (from Test #1). Vent all air through the vent hose by opening the vent needle valve. Close the vent needle valve only (The high side control needle valve is to remain open.).
2. Attach the vent hose from the gauge to the #4 test cock, then open the #4 test cock. Bleed water from the zone by opening the low side bleed needle valve on the gauge order to re-establish the normal reduced pressure within the zone. Once the gauge reading reaches a value above the #1 check valve pressure drop, close the low side bleed needle valve.

3. Open the vent needle valve. If the indicated differential pressure reading remains steady then the #2 check valve is reported as "closed tight." Go to Test #3. If the differential pressure reading falls to the relief valve opening point, bleed water through the low side bleed needle valve until the gauge reading reaches a value above the #1 check valve pressure drop. If the gauge reading settles above the relief valve opening point, record the #2 check valve as "closed tight," and proceed to Test #3. If the differential pressure reading falls to the relief valve opening point again, then the #2 check valve is noted as "leaking," and Test #3 cannot be completed. If the differential pressure reading drops, but stabilizes above the relief valve opening point, the #2 check valve can still be reported as "closed tight."

Note: Due to disc compression, you may need to bleed off water through low side bleed needle valve several times before the gauge reading will settle above relief valve opening point.

TEST NO.3 - TIGHTNESS OF #1 CHECK VALVE

REQUIREMENT:

The static pressure drop across #1 check valve shall be greater than the relief valve opening point (test #1), and at least 5.0 psid.

PROCEDURE:

1. With the vent hose connected to test cock #4 as in step 3 of Test #2, bleed water from the zone through the low side bleed needle valve on the gauge until the reading exceeds the #1 check valve pressure drop. Close the low side bleed needle valve. After the gauge reading settles, the steady state differential pressure reading indicated (reading is not falling on the gauge) is the actual static (i.e., no flow) pressure drop across check valve #1 and is to be recorded as such.
2. Close all test cocks, slowly open shutoff valve #2 and remove equipment.

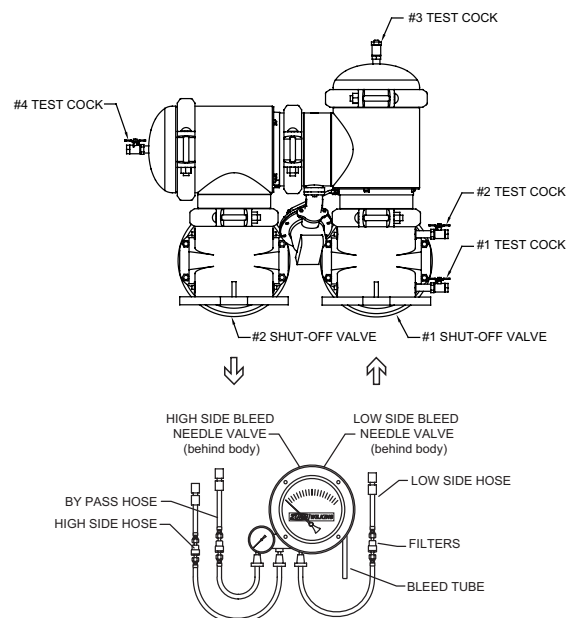

Proper performance is dependent upon licensed, qualified personnel performing regular, periodic testing according to ZURN WILKINS' specifications and prevailing governmental & industry standards and codes and upon following these installation instructions. Failure to do so releases ZURN WILKINS of any liability that it might otherwise have with respect to that device. Such failure could also result in an improperly functioning device.

Maintenance Instructions

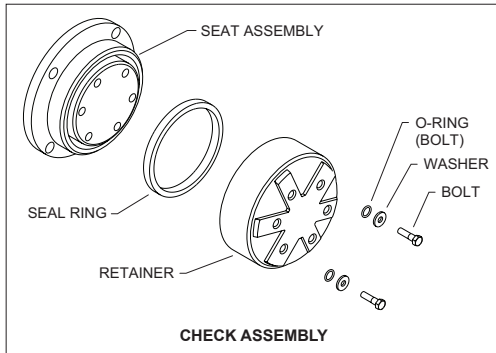

All Model 475ST Reduced Pressure Principle Backflow Preventers must be inspected and maintained by licensed personnel at least once a year or more frequently as specified by local codes. Replacement of worn or damaged parts must only be made with genuine "ZURN WILKINS" parts.

GENERAL MAINTENANCE

1. Clean all parts thoroughly with water after disassembly.
2. Carefully inspect rubber seal rings and o-rings for damage.
3. Test unit after reassembly for proper operation (refer to "TESTING PROCEDURES").

SERVICING RELIEF VALVE

1. Remove relief valve cover bolts and cover. Gently pull on diaphragm to remove the cartridge assembly.
2. Inspect seal ring for cuts and embedded debris. Turn over or replace if required.
3. Disassemble cartridge by unscrewing relief valve retainer screw.
4. Inspect diaphragm and o-rings for damage. Replace required parts and apply a light coat of lubricant to plunger o-ring.
5. Carefully reassemble cartridge assembly.
6. Inspect relief valve seat for wear on seating surface. If damaged, replace seat and seat o-ring. Install spring over seat guides.
7. Insert cartridge assembly into relief valve body.
8. Replace relief valve cover and cover bolts.
9. Place the device in service and test per "TESTING PROCEDURES" on page 2.

RELIEF VALVE ASSEMBLY

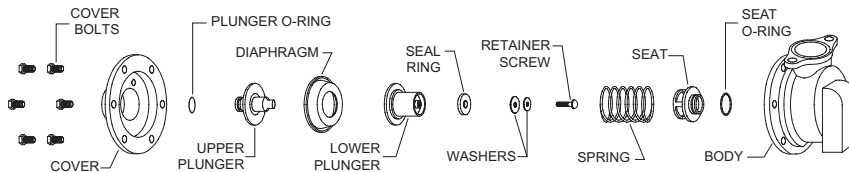

Pipe size	Capacity thru Schedule 40 Pipe			
	5 ft/sec	7.5 ft/sec	10 ft/sec	15 ft/sec
2 1/2"	75	112	149	224
3"	115	173	230	346
4"	198	298	397	595
6"	450	675	900	1351
8"	780	1169	1559	2339
10"	1229	1843	2458	3687

SERVICING CHECK VALVES

1. Close inlet and outlet shut-off valves.
2. Open No. 2, No. 3 and No. 4 test cocks to release pressure from valve.
3. Loosen & remove the grooved coupling around the access covers. Remove covers.
4. To service the #1 or #2 check assembly, remove the 6 bolts, washers and o-rings from the back of the #1 check assembly. Separate the retainer and the seal ring from the check assembly and proceed to step #7.

NOTE: Disassembly of the seat assembly is not recommended. If the seat assembly needs repair, please contact factory.

ALTERNATELY

5. To service both checks. Remove the 4 nuts and washers retaining the #1 check assembly. Remove the check assembly from the body.
6. Remove all 6 bolts, washers and o-rings from the check assembly (See "Check Assembly" illustration). Separate retainer from check assembly to expose seal ring for inspection.
7. Inspect the rubber seal ring for cuts or embedded debris. If the reverse side of the seal ring is unused, it is possible to invert the seal ring. This would be considered a temporary solution to fixing a fouled check and should be replaced with a new seal ring as soon as possible.
8. Inspect valve cavity and seating areas. Remove any debris.
9. Reverse the above procedures to reinstall check assemblies. Lubricate seat o-rings to hold them in place while reinstalling seat. Place washers on studs and tighten retaining nuts evenly.
10. Reinstall access cover and grooved coupling.

NOTE: If any portion of the seat assembly is damaged or missing or if the seat sealing rib is damaged in any way, do not attempt to field repair it. Contact your local ZURN WILKINS representative for assistance.

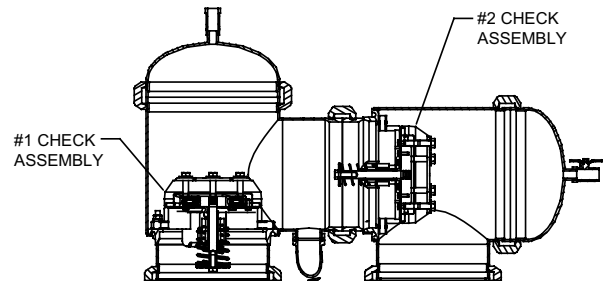

SPECIFICATIONS

Maximum working water pressure:	175 PSI
Maximum working water temperature:	140°F
Hydrostatic test pressure:	350 PSI
End connections:	Flanged ANSI B16.1 Class 125

Troubleshooting

PROBLEM

- SUDDEN OR RAPID SPITTING
- LIGHT INTERMITTENT DRIP
- CONTINUOUS DISCHARGE

POSSIBLE CAUSES

- Drop in inlet pressure.
- Sudden increase in downstream pressure due to waterhammer from quick closing shut-off valve installed downstream.
- Slightly fouled #1 check.
- Slightly fouled relief valve seat.
- Fouled #1 check and/or #2 check.
- Fouled relief valve seat.

CORRECTIVE ACTION

- Install an in-line spring loaded check valve or pressure reducing valve upstream of Backflow Preventer.
- Install an in-line spring loaded check valve or pressure reducing valve downstream of Backflow Preventer.
- Clean #1 check and/or turn check valve seal ring over or replace.
- Clean relief valve seat and/or turn relief valve seal ring over or replace.
- Clean check valves and/or turn check valve seal ring over or replace.
- Clean relief valve seat and/or turn relief valve seal ring over or replace.

Performance Characteristics

MODEL 475ST & 475STV 8" & 10" (STANDARD & METRIC)

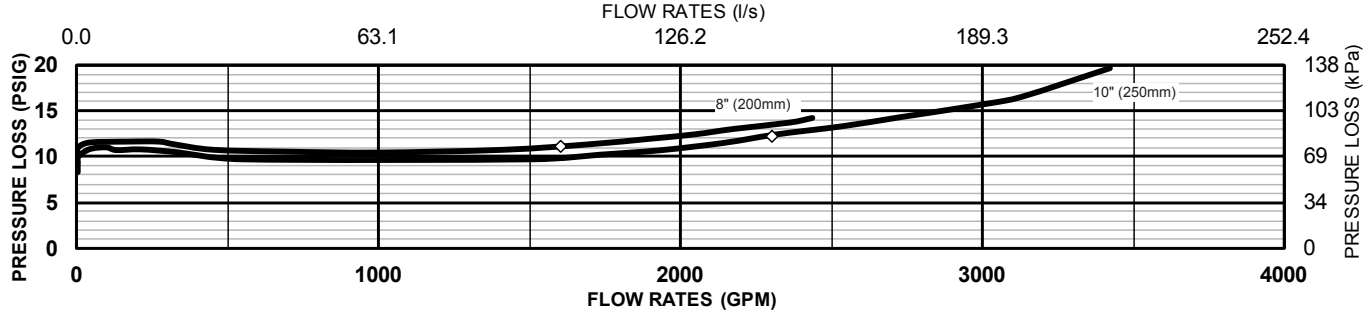

MODEL 475STDA & 475STDAV 8" & 10" (STANDARD & METRIC)

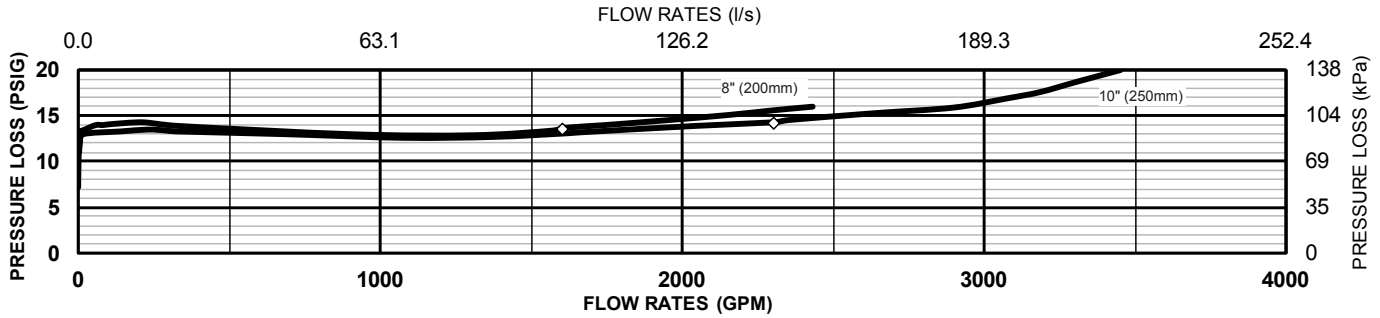

MODEL 475STR & 475STRV 8" & 10" (STANDARD & METRIC)

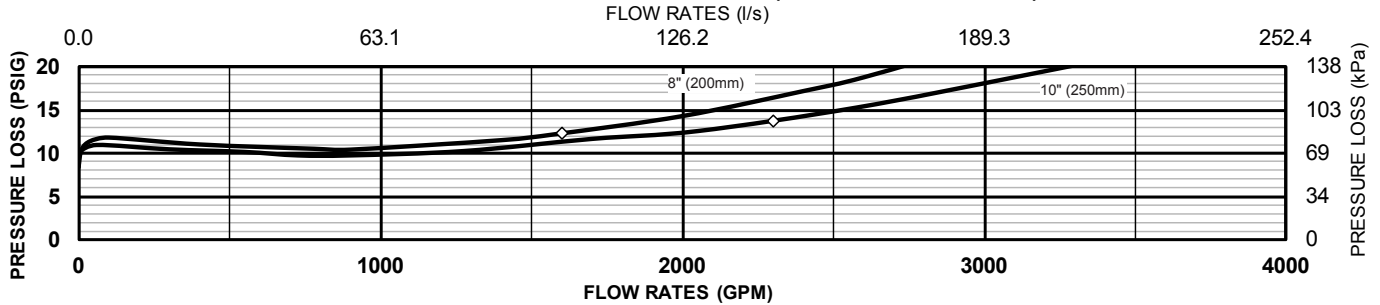

MODEL 475STDAR & 475STDARV 8" & 10" (STANDARD & METRIC)

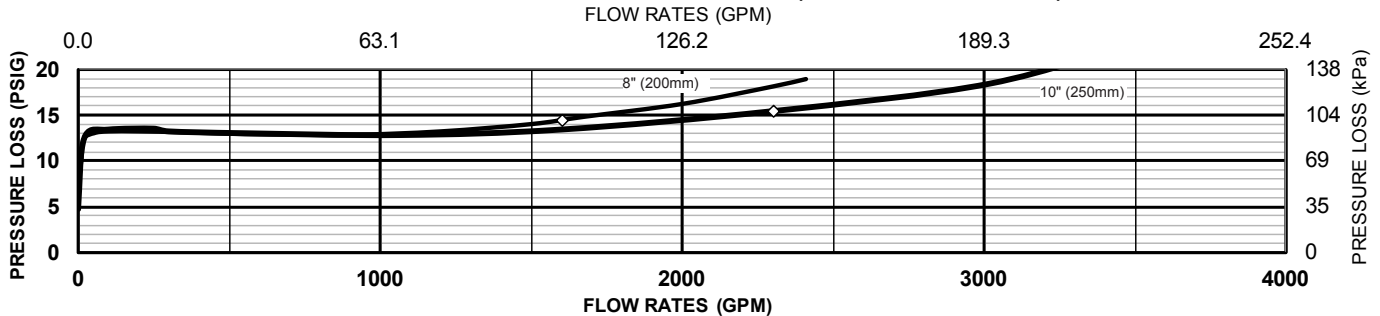

◇ Rated Flow (Established by approval agencies)

