

Pressure Vacuum Breaker

420 MODEL

Protection from
sudden spring AND
fall freezes!

FEATURES:

- Sizes 1/2", 3/4", 1"
- Pressure vacuum breaker consisting of an approved check valve, vacuum relief air inlet and outlet full port resilient seated ball valves for shut-off and two resilient seated ball valve test cocks.
- Integral relief valve reduces the risk of valve damage under light freezing conditions.
- Drop-in replaceable seat
- Thermoplastic modular cartridge design
- Temperature range 33°F - 140°F
- Maximum pressure 175 psi



Untimely spring or fall freezes can ruin your irrigation system and destroy your backflow preventer!

Now you can avoid costly valve or parts replacement by installing a Wilkins Model 420 Pressure Vacuum Breaker.

By discharging a small amount of water through a relief valve mounted in the poppet, the valve body and internal parts are protected from damage from spring and fall freezes. Because the 420 will not guard against severe freezes, care must be taken to winterize the valve properly.

The Wilkins Model 420 Pressure Vacuum Breaker, your best protection from sudden spring and fall freezes.

See your Wilkins representative or call for the distributor nearest you.

WILKINS
a **ZURN** company

Call 877-222-5356 or 805-226-6297
Customer Service Representatives
available Monday-Friday
5:30 am to 5:00 pm PST
www.zurn.com

Model 420

Pressure Vacuum Breaker Assembly with Integral Anti-Freeze Relief Valve



APPLICATION

Designed for installation on potable water lines to protect against backsiphonage of contaminated water into the potable water supply. Supplied with an integral anti-freeze relief valve to reduce the risk of valve damage under intermittent, non-seasonal freezing conditions. Designed for use under continuous pressure. Assembly shall provide protection where a potential health hazard exists.

FEATURES

Sizes: 3/4" 1"

Maximum working water pressure 175 PSI
 Maximum working water temperature 140°F
 Hydrostatic test pressure 350 PSI
 Threaded connections ANSI B1.20.1

Integral anti-freeze relief valve
 Replaceable thermoplastic modular cartridge

OPTIONS

(Suffixes can be combined)

- with full port QT ball valves (standard)

ACCESSORIES

- Repair kit (complete)
- Repair kit (rubber only)
- Repair kit (freeze kit)
- Water hammer arrester (Model 1250)

STANDARDS COMPLIANCE

- ASSE® Listed 1020
- IAPMO® Listed
- CSA® Certified
- Approved by the Foundation for Cross Connection Control and Hydraulic Research at the University of Southern California

MATERIALS

Main valve body Cast Bronze ASTM B 584
 Elastomers Silicone (FDA Approved)
 Buna Nitrile (NSF Listed)
 Polymers Polypropylene (FDA Approved)
 Delrin™ (NSF Listed)
 Noryl™ (NSF Listed)
 Springs Stainless Steel, 300 Series

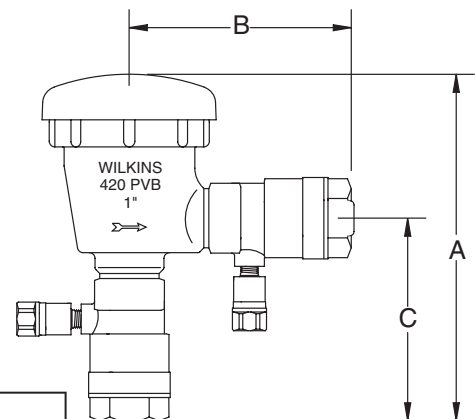

DIMENSIONS & WEIGHTS (do not include pkg.)

MODEL SIZE		DIMENSIONS (approximate)						WEIGHT	
		A		B		C			
in.	mm	in.	mm	in.	mm	in.	mm	lbs.	kg
3/4	20	6 3/4	172	4 1/4	108	3 13/16	97	4	1.8
1	25	7 15/16	202	4 15/16	125	4 1/2	114	5	2.3

WILKINS
 a **ZURN** company

Call 877-222-5356 or 805-226-6297
 Customer Service Representatives available
 Monday-Friday 5:30 am to 5:00 pm PST
www.zurn.com