

Design and Dimensional Data (inches and [ mm ]) are Subject to Manufacturing Tolerances and Change Without Notice

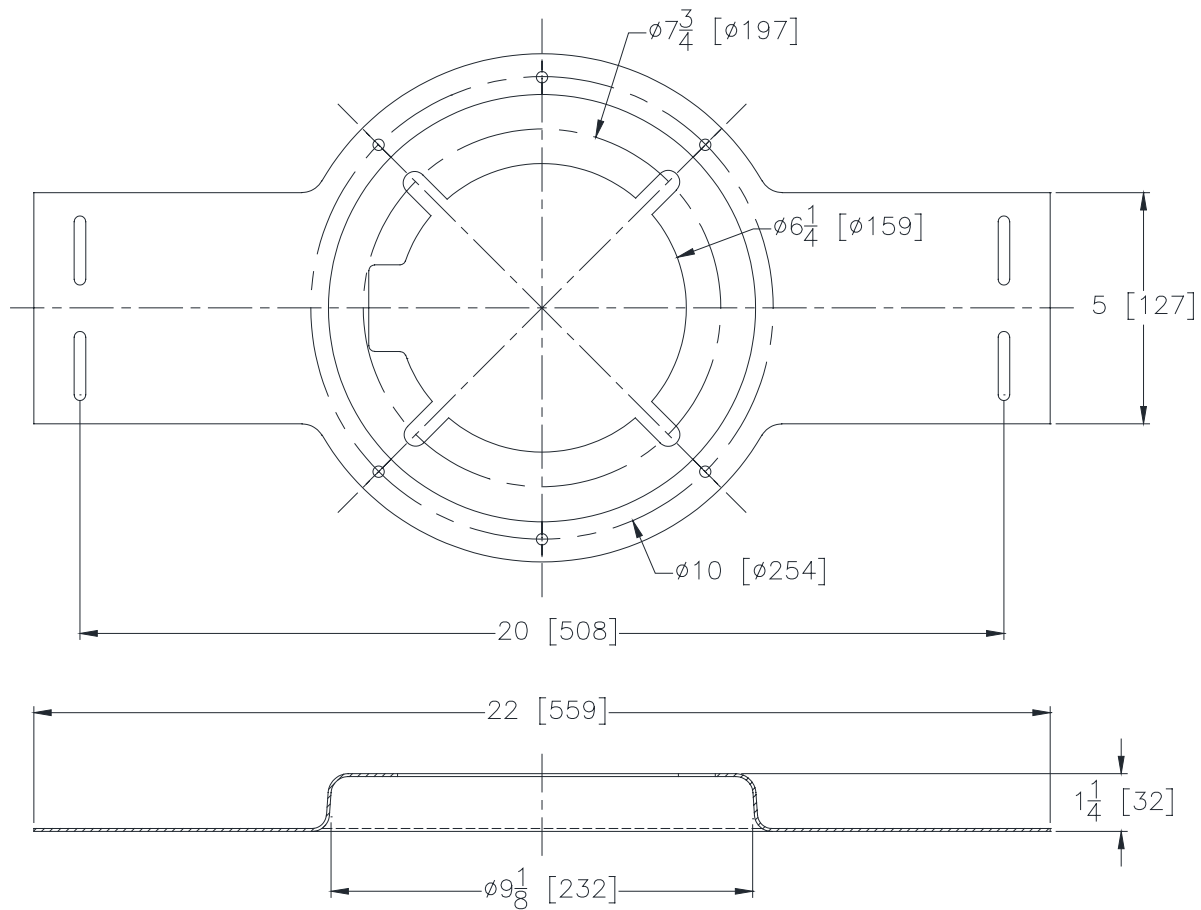

**ENGINEERING SPECIFICATION: ZURN Z1035-Q**

Structural Deck Drain Stabilizer for Q-deck. #16 gage galvanized steel plate with four support stud slots, and six nail holes. Complete with hardware bag containing four 3/8-16 x 12 [305] long studs and eight 3/8-16 flange locknuts.

**NOTE:** For use with 8-3/8 [213] dia. drain body.

**⚠ WARNING:** Cancer and Reproductive Harm - [www.P65Warnings.ca.gov](http://www.P65Warnings.ca.gov)

**⚠ ADVERTENCIA:** Cáncer y daño reproductivo - [www.P65Warnings.ca.gov](http://www.P65Warnings.ca.gov)

**⚠ AVERTISSEMENT:** Cancer et effets néfastes sur la reproduction - [www.P65Warnings.ca.gov](http://www.P65Warnings.ca.gov)

Zurn Industries, LLC | Specification Drainage Operation  
 1801 Pittsburgh Avenue, Erie, PA 16502, Ph. 855.663.9876

In Canada | Zurn Industries Limited  
 7900 Goreway Drive, Unit 10, Brampton, Ontario L6T 5W6, Ph. 877.892.5216

[www.zurn.com](http://www.zurn.com)

Rev.	D
Date:	11/25/2022
C.N. No.	144898
Patent	<a href="http://zurn.com/patents">zurn.com/patents</a>
Prod.   Dwg. No.	Z1035-Q