

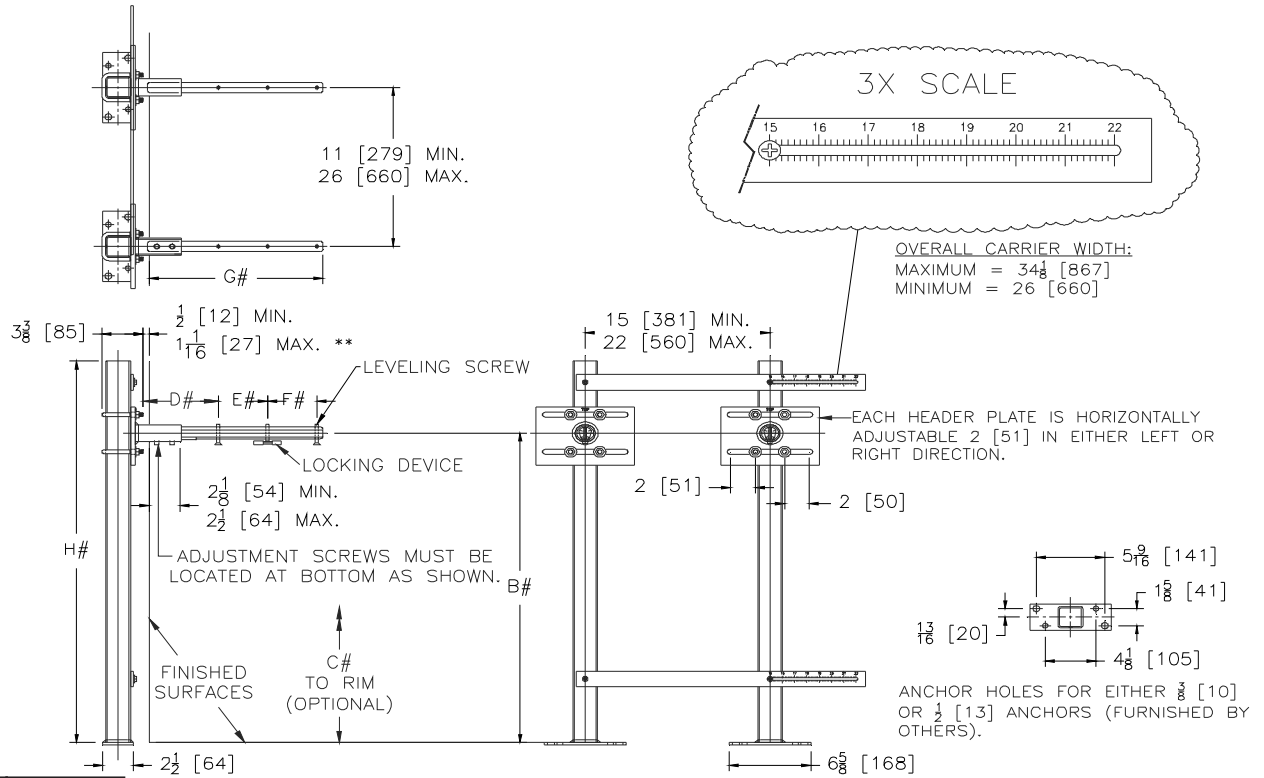

# Z1231-EZR

## CONCEALED ARM CARRIER SYSTEM FOR WALL HUNG LAVATORY W/ ADJUSTABLE UPRIGHTS & HEADER PLATES TAG \_\_\_\_\_

Dimensional Data (inches and [ mm ]) are Subject to Manufacturing Tolerances and Change Without Notice



Product No.	Approx. Wt. Lbs. [kg]
Z1231-EZR	45 [20]

NOTES:  
 #REFER TO ROUGH-IN GUIDE OF SPECIFIC FIXTURE FOR DIMENSION  
 \*\* WITH STANDARD SLEEVE LENGTH OF 4 [102]

**Note:**  
 Two diagonally spaced anchors per foot are required for correct installation.

### ENGINEERING SPECIFICATION: ZURN Z1231-EZR

Wall Hung Lavatory Support System complete with Dura-Coated upright supports made from structural carbon-steel square tubing, conforming to ASTM A500 Grade C standards, with welded steel plate mounting feet featuring separate bolt patterns for using either 3/8" [10mm] or 1/2" [13mm] anchors, both meeting OSHPD spacing requirements. Includes lower and upper EZ-installation plates, marked with an indexed ruler guide for accurate adjustability of upright spacing, from 15" [381mm] to 22" [560mm]. Individual slotted header plates with integral welded arm sleeves provide 2" [51mm] of additional horizontal adjustment per plate allowing for a total horizontal adjustment range of 11" [279mm] to 26" [660mm]. Arms are Dura-Coated cast iron and include leveling screws and soft-set elastomeric locking devices. Uprights, EZ-installation plates, and header plates are all factory assembled for easy installation. Carrier system exceeds load and deflection requirements when tested in accordance to ASME Standard A112.6.1M at any adjustment position.

### OPTIONS (Check/specify appropriate options)

#### PREFIXES

\_\_\_ Z Dura-Coated System with Support Plate\*

#### SUFFIXES

- \_\_\_ -AL Adapter Lug
- \_\_\_ -D Back to Back System
- \_\_\_ -E2 Concealed Arm Escutcheons 2 [51] Long
- \_\_\_ -WL Waste Line Sleeve

\* Regularly furnished unless otherwise specified.