



Model 450DA

Double Check Detector Assembly

Application

Designed for installation on water lines in fire protection systems to protect against both backsiphonage and backpressure of polluted water into the potable water supply. Assembly shall provide protection where a potential health hazard does not exist.

Standards Compliance

(Unless otherwise noted, applies to sizes 4" thru 10")

- ASSE® Listed 1048
- CSA® Certified B64.5 (4" & 6")
- AWWA Compliant C 510, and C550
- UL® Classified
- C-UL® Classified
- FM® Approved
- NYC MEA 26-00-M VOL 3
- Approved by the Foundation for Cross Connection Control and Hydraulic Research at the University of Southern California
- Meets the requirements of NSF/ANSI/CAN 61*

*(0.25% MAX. WEIGHTED AVERAGE LEAD CONTENT)

Materials

Main valve body	Ductile Iron ASTM A 536 Grade 4
Access covers	Ductile Iron ASTM A 536 Grade 4
Coatings	FDA Approved fusion epoxy finish
Fasteners	Stainless Steel, 300 Series
Elastomers	EPDM (FDA approved) Buna Nitrile (FDA approved)
Polymers	NORYL™
Springs	Stainless Steel, 300 series

Features

Sizes:	4", 6", 8", 10"
Maximum working water pressure	175 PSI
Maximum working water temperature	140°F
Hydrostatic test pressure	350 PSI
End connections (Grooved for steel)	AWWA C606
(Flanged)	ANSI B16.42
	Class 150

Dimensions & Weights (do not include pkg.)

MODEL 450DA SIZE	WEIGHT										
	LESS SHUTOFF VALVES		OS&Y GATE (GXF)		OS&Y GATE (GXG)		WITH BFLY (GXF)		WITH BFLY (GXG)		
	in.	mm	lbs.	kg	lbs.	kg	lbs.	kg	lbs.	kg	
4	100	105	48	295	134	271	123	175	79	153	69
6	150	174	79	474	215	452	205	278	126	248	112
8	200	402	182	878	398	824	374	592	269	546	248
10	250	420	191	1076	488	1018	462	694	315	636	288

MODEL 450DA SIZE	DIMENSIONS (approximate)																
	A		B WITH GATE VALVES		B WITH BFLY VALVES		B LESS GATE VALVES		C OS&Y OPEN		C OS&Y CLOSED		C WITH BFLY VALVES		D		
	in.	mm	in.	mm	in.	mm	in.	mm	in.	mm	in.	mm	in.	mm	in.	mm	
4	100	18 5/16	465	30	762	27 3/4	705	21	533	22 3/4	578	18 1/4	460	9	229	8	203
6	150	18 11/16	475	35 1/2	902	32 1/8	816	25	635	30 1/8	765	23 3/4	603	10 1/4	260	10	254
8	200	29	737	46	1168	42 9/16	1081	34 7/16	845	37 3/4	959	29 1/4	743	12	305	13	330
10	250	29	737	47 1/2	1207	47 1/2	1207	34 7/16	845	45 3/4	1162	35 3/8	899	13	330	13	330



LEAD FREE



NSF/ANSI/CAN 61

Options

(Suffixes can be combined)

- with OS & Y gate valves (standard)
- L - less shut-off valves (grooved body connections)
- LM - less water meter
- with gpm meter (standard)
- CFM - with cu ft/min meter
- G - with groove end gate valves
- FG - with flanged inlet gate connection and grooved outlet gate connection
- FSC - with epoxy coated wye type strainer (flanged only)
- BG - with grooved end butterfly valves with integral supervisory switches
- BF - with flanged end butterfly valves with integral supervisory switches
- PI - with Post Indicator Gate Valve

Accessories

- Repair kit (rubber only)
- Thermal expansion tank (Model XT)
- Valve setter (Model FLS or MJS or MJFS)
- Gate valve tamper switch (OSY-40)
- QT-SET Quick Test Fitting Set

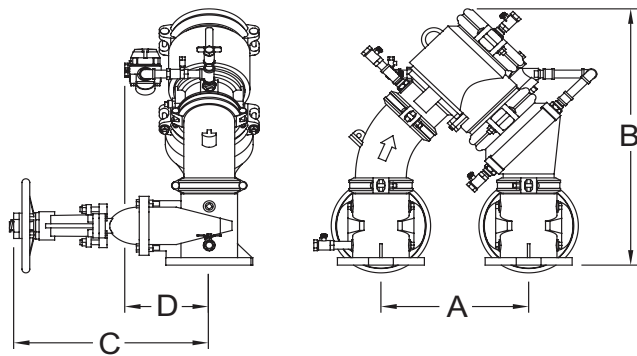

MODEL 450DA 4" & 6" (STANDARD & METRIC)

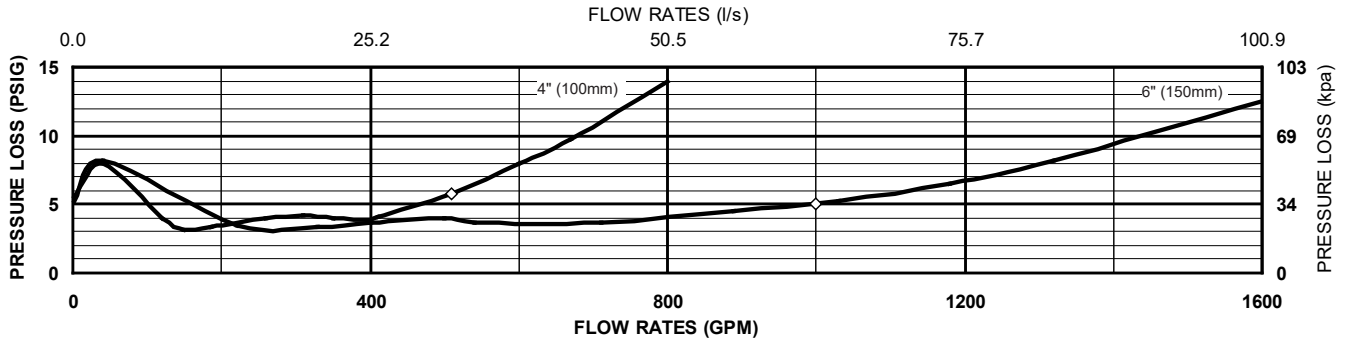

MODEL 450DA 8" & 10" (STANDARD & METRIC)

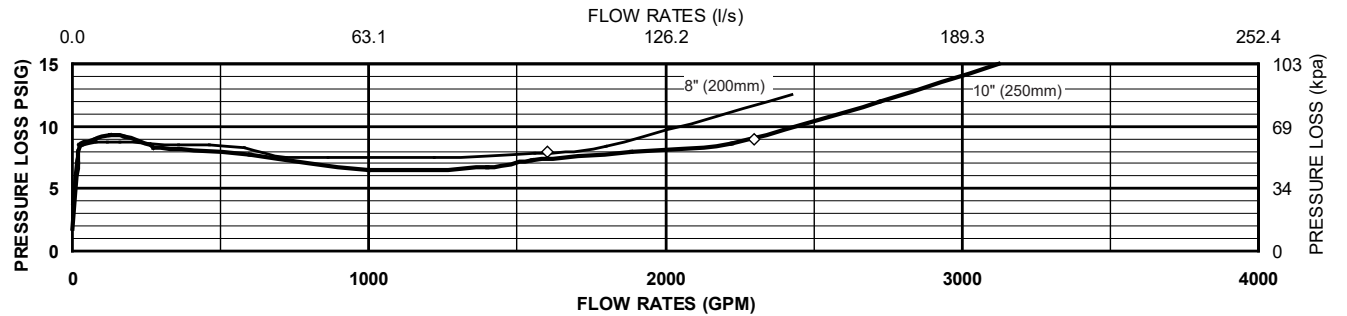

Typical Installation

Local codes shall govern installation requirements. To be installed in accordance with the manufacturer's instructions and the latest edition of the Uniform Plumbing Code. Unless otherwise specified, the assembly shall be mounted above adequate drains with sufficient side clearance for testing and maintenance. The installation shall be made so that no part of the unit can be submerged.

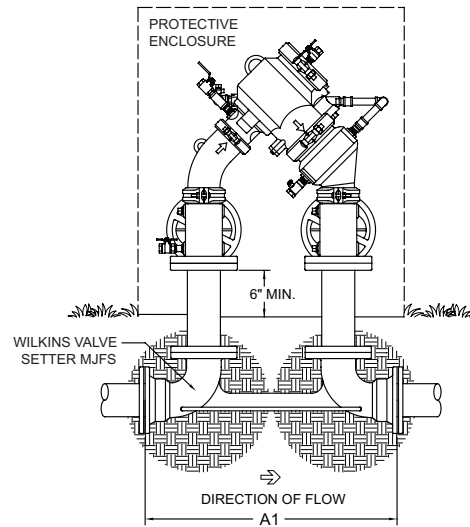

OUTDOOR INSTALLATION

Capacity thru Schedule 40 Pipe (GPM)				
Pipe size	5 ft/sec	7.5 ft/sec	10 ft/sec	15 ft/sec
2 1/2"	75	112	149	224
3"	115	173	230	346
4"	198	298	397	595
6"	450	675	900	1351
8"	780	1169	1559	2339
10"	1229	1843	2458	3687

MODEL SIZE		DIMENSIONS (approximate)			
		A1 SETTER END TO END FLS		A1 SETTER END TO END MJS	
in.	mm	in.	mm	in.	mm
4	100	31 5/16	795	29.313	745
6	150	34 3/4	884	32.75	832
8	200	47	1194	44.625	1133
10	250	51	1295	47	1194

Specifications

The Double Check Detector Backflow Preventer shall be certified to NSF/ANSI/CAN 61, ASSE® Listed 1048 and supplied with full port OS & Y gate valves. The main body and access cover shall be epoxy coated ductile iron (ASTM A 536 Grade 4), the seat ring and check valve shall be NORYL™, the stem shall be stainless steel (ASTM A 276) and the seat disc elastomers shall be EPDM. The checks shall be accessible for maintenance without removing the device from the line. The Double Check Detector Backflow Preventer shall be a ZURN WILKINS Model 450DA.