



Model FP23 Couplings



Application

Zurn Model FP23 couplings join together grooved pipe, fittings, valves, and accessories. FP23 couplings are available in Rigid Angle Pad, Flexible, and Reducing options. Qualified for use on wet and dry pipe fire protection systems.

- **Rigid Angle Pad Couplings** provide sturdy inflexible joints comparable to flanged, welded, or threaded connections. They are designed to prevent angular and axial deflection of connected pipes.
- **Flexible Couplings** allow joints to flex at the connection without leakage. They meet flexure requirements for structural settling, inter-building piping, and seismic motion.
- **Reducing Couplings** provide a flexible style joint between pipes of different sizes. Each reducing coupling makes a connection that would otherwise require two separate couplings and a reducer.

Materials

Casting ASTM A536 65-45-12 Ductile Iron
 Gasket EPDM, Pre-lubricated, Pressure responsive
 Bolts & Nuts Grade 5

Standards Compliance

- UL[®] Listed
- C-UL[®] Listed
- FM[®] Approved

Features

Maximum Pressure: 300 PSI

Options

- RA - Rigid Angle Pad Couplings
- F - Flexible Couplings
- GALV - With Hot Dipped Galvanized Coating



4-FP23RA



4X2-FP23



Model FP23RA

Rigid Angle Pad Couplings



4-FP23RA

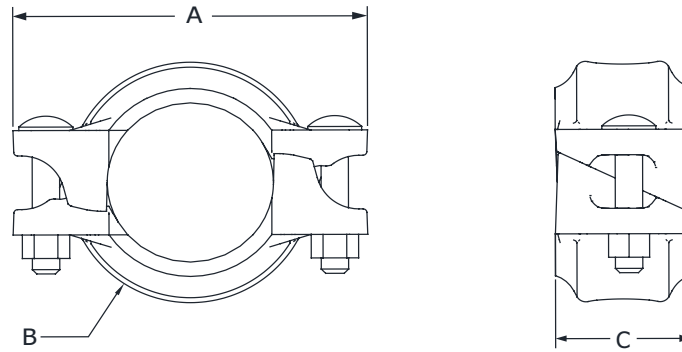

Dimensions & Weights (do not include pkg.)

SIZE in.	MODEL	DIMENSIONS (approximate)			
		A in.	B in.	C in.	Weight lb.
1 1/4	114-FP23RA	4.17	2.57	1.85	1.3
1 1/2	112-FP23RA	4.37	2.77	1.85	1.3
2	2-FP23RA	4.86	3.35	1.85	1.6
2 1/2	212-FP23RA	5.41	3.89	1.85	1.8
3	3-FP23RA	6.48	4.61	1.87	2.4
4	4-FP23RA	7.40	5.53	2.05	2.9
6	6-FP23RA	9.80	7.87	2.07	4.9
8	8-FP23RA	12.60	9.89	2.52	8.8
10	10-FP23RA	15.75	12.44	2.60	17.4
12	12-FP23RA	17.95	14.49	2.60	22.7



Model FP23F

Flexible Fire Couplings



4-FP23F

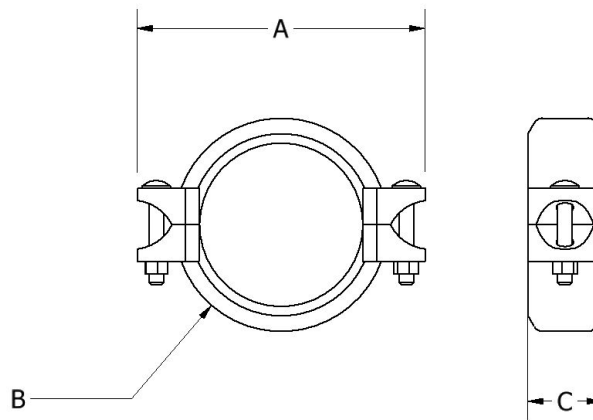

Dimensions & Weights (do not include pkg.)

SIZE in.	MODEL	DIMENSIONS (approximate)			
		A in.	B in.	C in.	Weight lbs.
1 1/4	114-FP23F	4.21	2.64	1.73	1.2
1 1/2	112-FP23F	4.37	2.84	1.73	1.2
2	2-FP23F	4.88	3.35	1.73	1.5
2 1/2	212-FP23F	5.43	3.90	1.77	1.7
3	3-FP23F	6.50	4.57	1.77	2.4
4	4-FP23F	7.48	5.55	1.93	3.1
6	6-FP23F	9.84	7.87	1.93	4.5
8	8-FP23F	12.56	9.96	2.32	8.3



Model FP23

Reducing Couplings



4X2-FP23

Dimensions & Weights (do not include pkg.)

SIZE in.	MODEL	DIMENSIONS (approximate)			
		A in.	B in.	C in.	Weight lbs.
1 1/2 X 1 1/4	112X114-FP23	4.55	2.88	1.77	1.3
2 X 1 1/2	2X112-FP23	5.08	3.54	1.85	1.9
2 1/2 X 1 1/2	212X112-FP23	5.39	3.98	1.89	2.6
2 1/2 X 2	212X2-FP23	5.39	3.98	1.89	2.2
3 X 1 1/2	3X112-FP23	6.46	4.72	1.89	3.8
3 X 2	3X2-FP23	6.46	4.72	1.89	3.2
3 X 2 1/2	3X212-FP23	6.46	4.72	1.89	3.2
4 X 2	4X2-FP23	7.68	5.91	1.93	4.6
4 X 2 1/2	4X212-FP23	7.68	5.91	1.93	4.4
4 X 3	4X3-FP23	7.68	5.91	1.93	4.3
6 X 3	6X3-FP23	9.25	7.99	1.97	7.6
6 X 4	6X4-FP23	9.25	7.99	1.97	7.4
8 X 6	8X6-FP23	12.32	10.39	2.36	15.1

