

**NOTES:**

- UNDER-THE-SINK GREASE INTERCEPTOR. FOR GRAVITY FLOW APPLICATIONS ONLY.
- INSTALL IN ACCORDANCE WITH MANUFACTURERS INSTRUCTIONS.
- Ø 3" NOMINAL POLY PIPE STUB INLET AND OUTLET.
- CONNECT INLET AND OUTLET TO DRAIN PIPING USING FLEXIBLE RUBBER COUPLINGS.
- NON REMOVEABLE BAFFLES.
- COVER NOT LOAD RATED.
- 20 YEAR WARRANTY.
- US PATENT 7,682,509 AND CANADIAN PATENT 2,712,499.

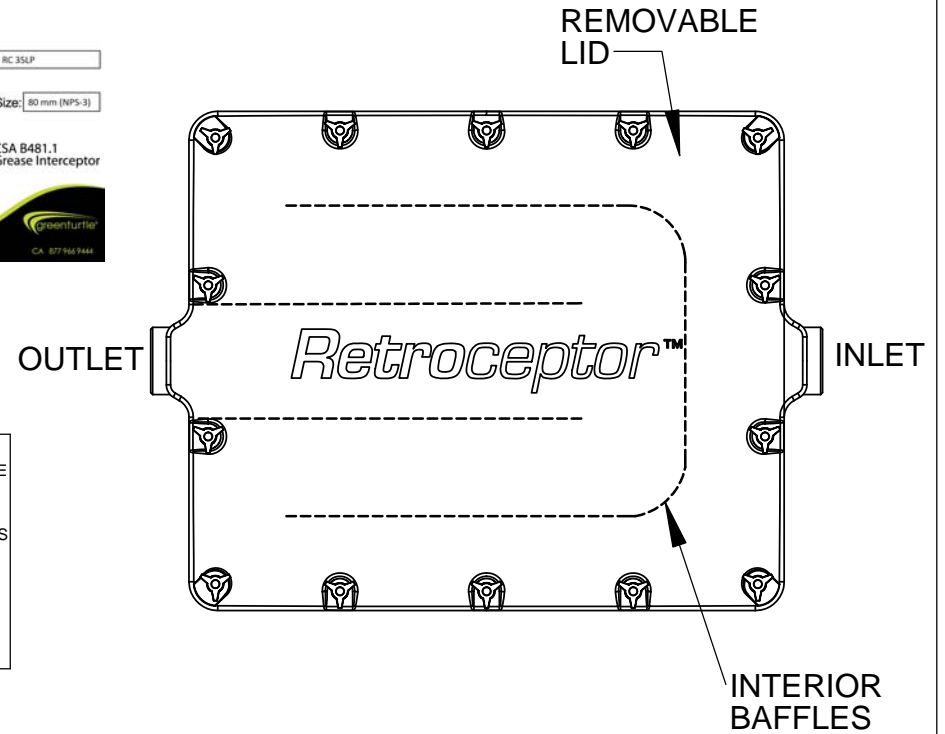

DETAIL "B"



VENTED FLOW CONTROL FOR PDI CERTIFIED INTERCEPTOR MUST BE INSTALLED PRIOR TO THE GREASE INTERCEPTOR IN THE WASTE LINE BEYOND THE LAST CONNECTION FROM THE FIXTURE AND AS CLOSE AS POSSIBLE TO THE UNDERSIDE OF THE LOWEST FIXTURE

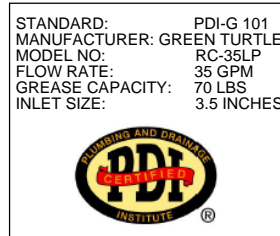

DETAIL "A"

DETAIL "A"  
USA ONLY

DETAIL "B"  
CANADA ONLY

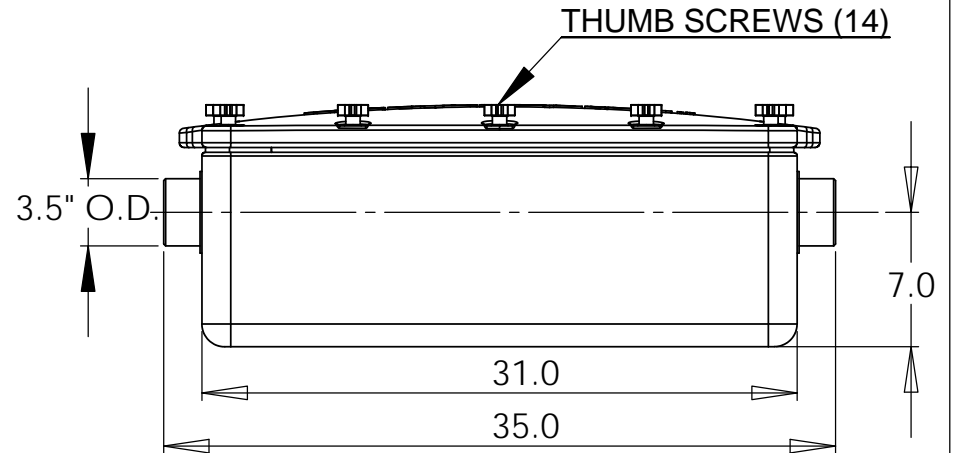
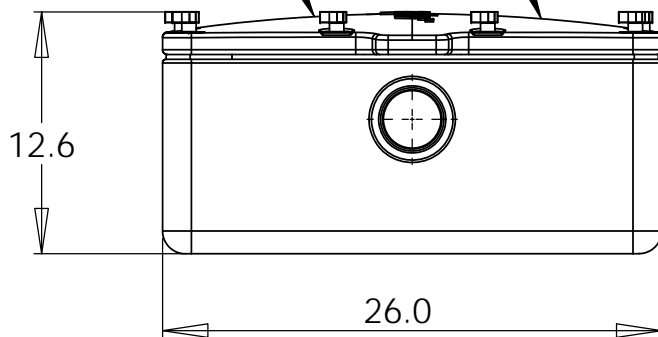

ALL DIMENSIONS IN INCHES

MATERIAL: Proprietary Polymer		NAME	DATE	TITLE:
WEIGHT [lb]: 45.3	DRAWN	LS	28 SEP 10	RC 35LP Retroceptor
DO NOT SCALE DRAWING	CHECKED			

DWG. NO: GT0161	REV: 5
SHEET 1 OF 1	SIZE: A
SCALE: 1:10	



THE INFORMATION CONTAINED IN THIS DRAWING IS THE SOLE PROPERTY OF GREEN TURTLE TECHNOLOGIES Ltd. ANY REPRODUCTION IN PART OR AS A WHOLE WITHOUT THE WRITTEN PERMISSION OF GREEN TURTLE TECHNOLOGIES Ltd. IS PROHIBITED.



*Retroceptor™*

*DEC 2015*

## Installation Manual

### PROCEDURE

Retroceptors are typically located under or in close proximity to the kitchen sink. For on-floor installations, go to section A. For in-ground installations, go to section B. For partial in-ground installations, go to section C. For non-standard installations, such as suspension from the ceiling, Retroceptors should only be suspended if they are supported by a rigid flat surface load-bearing platform designed and certified by a local professional engineer to support the entire weight of the retroceptor when full of water. Contact Zurn Green Turtle if you have any questions regarding installation.

**NOTE:** Proper installation is critical in ensuring the effective operation of the Retroceptor. Installation recommendations may be subject to local jurisdiction code requirements and approvals where applicable. Installation should be performed by licensed professionals.

**NOTE:** All installations must use the supplied external flow control device which is furnished with all Retroceptors. It is an important factor in the operation of the interceptor. The flow control device should be installed in the waste line upstream of the grease interceptor. It should be placed beyond the last connection from the fixture(s) and as close as possible to the underside of the lowest fixture. When two or more sinks or fixtures are combined and served by one interceptor, a single flow control fitting can be used.

The flow control device must be properly vented to permit air to mix with the fluid entering the interceptor. Air facilitates separation and, more importantly, is necessary to maintain the proper pressure, thus, the proper operating level within the separation chamber.

Air intake for the flow control device may terminate under the sink drain board, as high as possible, to prevent overflow or terminate in a return bend at the same height outside of the building. When a fixture is individually trapped and back vented, air intake may intersect the vent stack. All installation recommendations are subject to approval of code authority.

## Installation Manual

### A) ON-FLOOR INSTALLATION

- 1. Ensure that the installation area is a rigid and flat surface and free from any debris.
- 2. Ensure that the installation area provides clear access to the cover.
- 3. The installation area should have a minimum free space of 12 inches above the top of the cover for easy access. Failure to do this may interfere with proper maintenance.
- 4. Place the unit on the installation area. Allow room for piping connections.
- 5. Connect Retroceptor inlet and outlet stubs to piping on site. The inlet and outlet are straight polymer pipes.

Model	Outer Diameter
RC 35	3.5 INCH
RC 50	4.5 INCH

Zurn Green Turtle recommends the use of only flexible rubber (Fernco) couplings suitable for sewer and drainage applications unless forbidden by local code. Code approved materials should always be used to make the connections. Do not use shielded couplings. Do not apply any glue to the Retroceptor piping.

- 6. Ensure that the connections are water tight.
- 7. Provide vents as per local plumbing code. Zurn Green Turtle recommends that venting should be provided both upstream and downstream of the Retroceptor. Venting will promote gravity flow, prevent siphoning, and reduce odours.
- 8. Provide cleanouts as required. Zurn Green Turtle recommends that a cleanout tee be installed directly upstream of the Retroceptor for access to the flow control orifice at the inlet.
- 9. Fill the Retroceptor with clean water and ensure that all the fasteners are properly secured before starting operation.

## Installation Manual

### B) IN-GROUND INSTALLATION

Use this procedure together with the applicable installation drawing.

1. Ensure that the installation is no deeper than 12 inches from top of the cover to grade. Installations deeper than 12 inches will make it difficult to remove the cover.
  - a. In the case of installations deeper than 12 inches, an in-ground vault should be constructed on-site by local contractor.
2. Excavation for the installation of the Retroceptor must conform to OSHA and/or local excavation codes and standards. Top soil removed during excavation should not be used as backfill material.
3. Excavation should include an allowance for shoring and bracing where required.
4. A 6 inch high base layer of pea gravel (or approved equivalent compacted backfill compacted to 98% S.P.D.) must be installed and leveled at the bottom of the excavation.
5. Lower the Retroceptor onto the pea gravel. Adjust the position of the Retroceptor to ensure that the inlet and outlet pipes are in-line with the piping on site.
6. Backfill the area surrounding the Retroceptor using pea gravel up to the inlet invert.
7. Connect inlet and outlet to piping on site. The inlet and outlet are straight polymer pipes.

Model	Outer Diameter
RC 35	3.5 INCH
RC 50	4.5 INCH

Zurn Green Turtle recommends the use of only flexible rubber (Fernco) couplings suitable for sewer and drainage applications unless forbidden by local code. Code approved materials should always be used to make the connections. Do not use shielded couplings. Do not apply any glue to the Retroceptor piping.

8. Ensure that the connections are water tight.
9. Provide vents as per local plumbing code. Zurn Green Turtle recommends that venting should be provided both upstream and downstream of the Retroceptor. Venting will promote gravity flow, prevent siphoning, and reduce odours.
10. Provide cleanouts as required. Zurn Green Turtle recommends that a cleanout tee be installed directly upstream of the Retroceptor for access to the flow control orifice at the inlet.
11. Pour concrete from the top of the pea gravel to the floor level. Leave a gap between the concrete and the Retroceptor. Ensure that the concrete does not come into contact with any part of the Retroceptor.
12. Install a skid resistant access hatch at grade. Ensure that the access hatch is larger than the size of the Retroceptor cover dimensions for ease of maintenance.

## Installation Manual

- 13. The access hatch must be secured in concrete. Ensure the concrete being used is designed to support the weight of the access hatch and expected pedestrian and equipment traffic load.
- 14. Fill the Retroceptor with clean water and ensure that all the fasteners are properly secured before starting operation.

### C) PARTIAL IN-GROUND INSTALLATION

Use this procedure together with the applicable installation drawing.

- 1. Excavate the installation area to the required depth. Ensure that the inlet and outlet of the Retroceptor are at the same elevation as the piping on site.
- 2. Ensure that installation surface is rigid, flat, free from any debris, and able to support the weight of the Retroceptor filled with water.
- 3. Build a 4 inch high lip all around the excavated area to prevent any water on the kitchen floor from draining into the installation area.
- 4. Ensure that the installation area provides clear access to the cover.
- 5. The installation area should have a minimum free space of 12 inches above the top of the cover for easy access. Failure to do this may cause maintenance issues.
- 6. Place the unit on the installation area. Allow room for piping connections.
- 7. Connect inlet and outlet to piping on site. The inlet and outlet are straight polymer pipes.

Model	Outer Diameter
RC 35	3.5 INCH
RC 50	4.5 INCH

Zurn Green Turtle recommends the use of only flexible rubber (Fernco) couplings suitable for sewer and drainage applications unless forbidden by local code. Code approved materials should always be used to make the connections. Do not use shielded couplings. Do not apply any glue to the Retroceptor piping.

- 8. Ensure that the connections are water tight.
- 9. Provide vents as per local plumbing code. Zurn Green Turtle recommends that venting should be provided both upstream and downstream of the Retroceptor. Venting will promote gravity flow, prevent siphoning, and reduce odours.
- 10. Provide cleanouts as required. Zurn Green Turtle recommends that a cleanout tee be installed directly upstream of the Retroceptor for access to the flow control orifice at the inlet.
- 11. Fill the Retroceptor with clean water and ensure that all the fasteners are properly secured before starting operation.

## Installation Manual

### GRANULAR BACKFILL SPECIFICATION

#### PEA GRAVEL

Pea Gravel is a naturally rounded aggregate with a particle size not less than 3mm (1/8") and not greater than 18mm (3/4"). Gravel must be clean and free flowing, free from large rocks, dirt, sand, roots, organic materials or debris. Upon screening, analysis of the backfill material must have no more than 3% of its weight passing through a #8 sieve (2.38 mm square screen opening). Dry density must be a minimum of 96.3 lbs/ft<sup>3</sup>.

#### CRUSHED STONE (APPROVED EQUIVALENT TO PEA GRAVEL) – MUST BE COMPACTED

Crushed stone or gravel is not less than 3 mm (1/8") and not greater than 12mm (1/2"). Aggregate must be clean and free flowing, free from large rocks, dirt, sand, roots, organic materials or debris. Materials should be washed or screened to remove fine particles. Upon screening, analysis of the backfill material shall have no more than 3% of its weight passing through #8 sieve (2.38 mm square screen opening). Dry density must be a minimum of 95 lbs/ft<sup>2</sup>.

NOTES:

- REFER TO RETROCEPTOR DRAWING AND INSTALLATION MANUAL FOR INSTALLATION PROCEDURE.

MODEL	DIMENSIONS (INCHES)			
	A	B	C	INLET/OUTLET PIPE SIZE
RC 50	14.25	14.25	23	4
RC 35	17.25	17.25	25	3
RC 35 LP	5.25	5.25	13	3

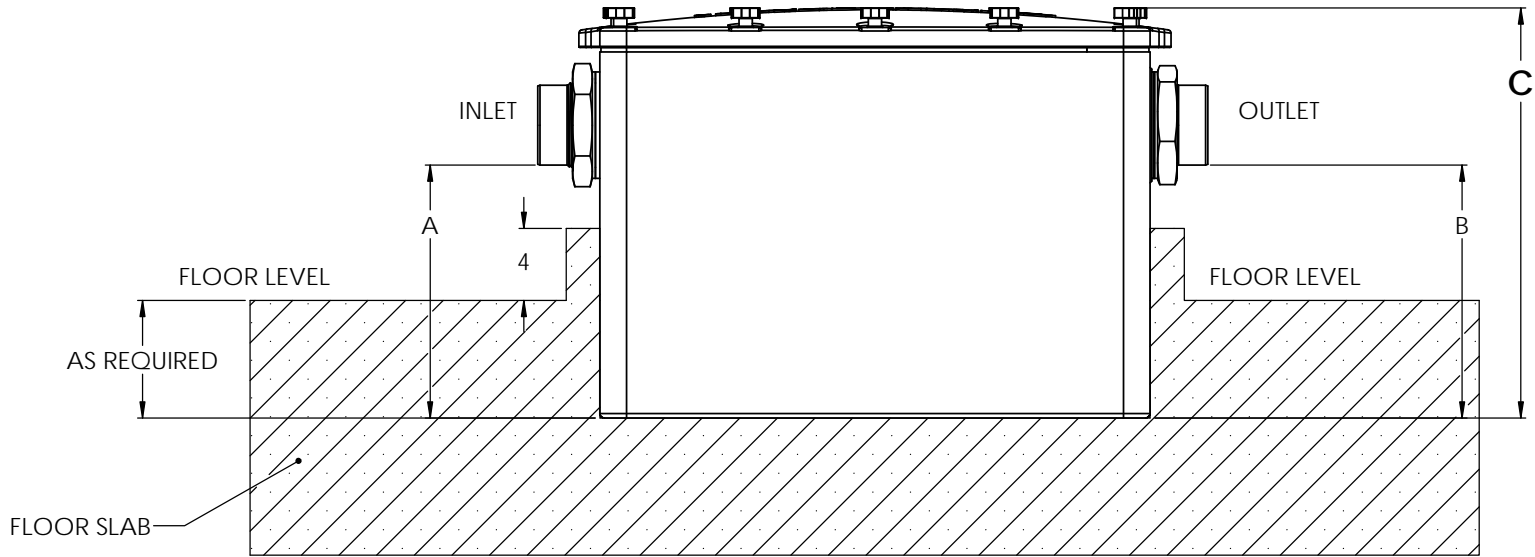

ALL DIMENSIONS IN INCHES	MATERIAL:			TITLE: <b>RETROCEPTOR PARTIAL BURIAL INSTALL</b>	DWG. NO: <b>GT0747</b>	REV:	
	WEIGHT (lb):	DRAWN	NAME		DATE	SHEET 1 OF 1	SIZE:
	DO NOT SCALE DRAWING	CHECKED	SM		20 FEB 2015	SCALE: 1:10	B
<small>THE INFORMATION CONTAINED IN THIS DRAWING IS THE SOLE PROPERTY OF GREEN TURTLE TECHNOLOGIES LTD. ANY REPRODUCTION IN PART OR AS A WHOLE WITHOUT THE WRITTEN PERMISSION OF GREEN TURTLE TECHNOLOGIES LTD. IS PROHIBITED.</small>							



8 7 6 5 4 3 2 1

NOTES:

- REFER TO RETROCEPTOR DRAWING AND INSTALLATION MANUAL FOR INSTALLATION PROCEDURE.

MODEL	DIMENSIONS (INCHES)			
	A	B	C	INLET/OULET PIPE SIZE
RC 50	14.25	14.25	23	4
RC 35	17.25	17.25	25	3
RC 35 LP	5.25	5.25	13	3

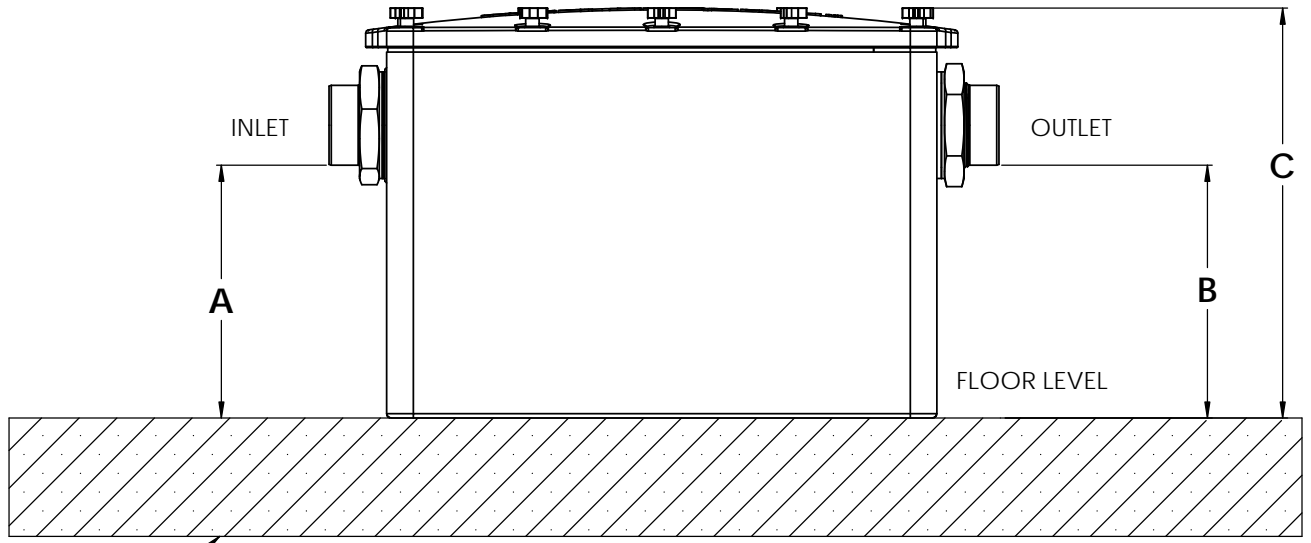

D  
B  
A

D  
C  
B

FLOOR SLAB

FLOOR LEVEL

MATERIAL:				TITLE: <b>RETROCEPTOR ON-FLOOR INSTALL</b>		DWG. NO: <b>GT0748</b>	REV:
WEIGHT (lb):	DRAWN	NAME	DATE			SHEET 1 OF 1	SIZE:
	SM		11/24/2016			SCALE: 1:7	B
DO NOT SCALE DRAWING	CHECKED						



THE INFORMATION CONTAINED IN THIS DRAWING IS THE SOLE PROPERTY OF GREEN TURTLE TECHNOLOGIES Ltd. ANY REPRODUCTION IN PART OR AS A WHOLE WITHOUT THE WRITTEN PERMISSION OF GREEN TURTLE TECHNOLOGIES Ltd. IS PROHIBITED.

8 7 6 5 4 3 2 1



**FRAME AND COVER**

1. SUPPLIED BY OTHERS UNLESS OTHERWISE STATED.
2. ENSURE OPENING IS LARGER THAN SIZE OF RETROCEPTOR.

PIPING AND COUPLINGS SUPPLIED BY OTHERS

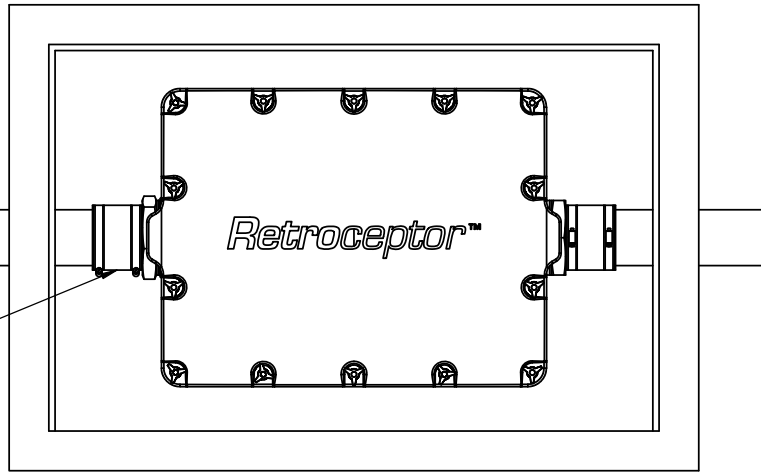

**NOTES:**

1. REFER TO RETROCEPTOR DRAWING AND INSTALLATION MANUAL FOR INSTALLATION PROCEDURE.

MODEL	DIMENSIONS (INCHES)					INLET/OUTLET PIPE SIZE
	A	B	C	D	E	
RC 50	14.25	14.25	31	23	24	4
RC 35	17.25	17.25	20	25	17	3
RC 35 LP	5.25	5.25	31	13	26	3

CONCRETE

INLET PIPE

OUTLET PIPE

PEA GRAVEL

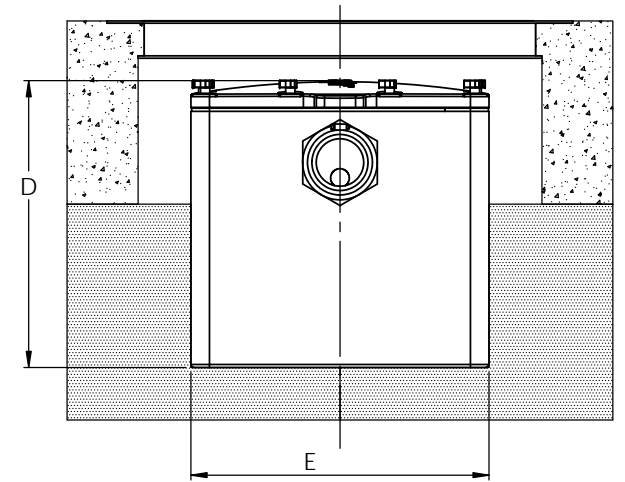
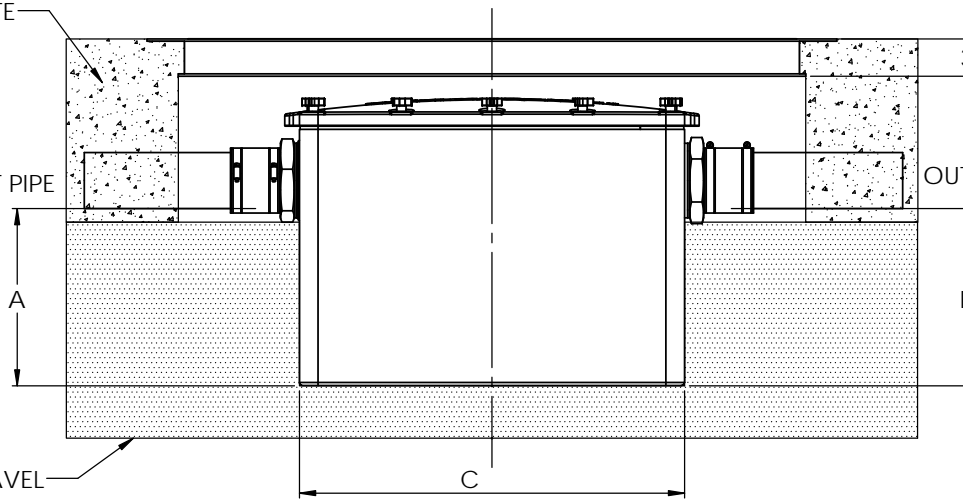

ALL DIMENSIONS IN INCHES UNLESS OTHERWISE STATED.	MATERIAL:			
	WEIGHT (lb):	DRAWN	NAME	DATE
			SM	20 FEB 2015
	DO NOT SCALE DRAWING	CHECKED		

TITLE: **RETROCEPTOR BURIED INSTALL**

DWG. NO:	REV:
<b>GT0749</b>	
SHEET 1 OF 1	SIZE:
SCALE: 1:10	<b>B</b>



THE INFORMATION CONTAINED IN THIS DRAWING IS THE SOLE PROPERTY OF GREEN TURTLE TECHNOLOGIES LLC. ANY REPRODUCTION IN PART OR AS A WHOLE WITHOUT THE WRITTEN PERMISSION OF GREEN TURTLE TECHNOLOGIES LLC IS PROHIBITED.