



# Model 600XL

## Water Pressure Reducing Valve with Integral By-pass Check Valve and Strainer

### Application

Zurn Wilkins model 600XL is designed for installation on potable water lines to reduce high inlet pressure to a lower outlet pressure. The integral strainer makes this device most suitable for residential and commercial water systems requiring frequent cleaning because of sediment and debris. The direct acting integral by-pass design prevents buildup of excessive system pressure caused by thermal expansion. The balanced piston design enables the regulator to react in a smooth and responsive manner to changes in system flow demand, while at the same time, providing protection from inlet pressure changes.

### Standards Compliance

- ASSE® Listed 1003
- IAPMO® Listed
- CSA® Certified
- City of Los Angeles Approved
- Meets the requirements of NSF/ANSI/CAN 61

### Materials

Main valve body	Low Lead Cast Bronze	ASTM B 584
Access covers	Low Lead Cast Bronze	ASTM B 584
	Low Lead Brass	
Fasteners	Stainless Steel, 300 Series	
Stem & plunger	Low Lead Cast Bronze	ASTM B 584
	Low Lead Brass	
Elastomers	Buna Nitrile, (FDA Approved)	
	EPDM, (FDA Approved)	
Cap gaskets	Natural Vulcanized Fibre	
	Acetal (Delrin™)	
Strainer screen	Stainless Steel, 300 Series	Strainer
Seat	Stainless Steel, 300 Series	

### Features

Sizes:	1/2", 3/4", 1", 1 1/4", 1 1/2", 2"
Maximum working water pressure	300 psi
Maximum working water temperature	140°F
Reduced pressure range (standard)	25 psi to 75 psi
Factory preset	50 psi
Hydrostatic test pressure	300 psi
CPVC tailpiece: Max. hot water temp.	140°F @ 100 psi
	Cold water rated temp. 73.4°F @ 400 psi

### Dimensions & Weights (do not include pkg.)

SIZE		CONNECTIONS	DIMENSIONS (approximate)								WEIGHT	
			A		B		C		D			
in.	mm		in.	mm	in.	mm	in.	mm	in.	mm	lbs.	kg.
1/2	15	SINGLE UNION	5 1/2	133	6 1/4	159	1 1/4	32	2 3/4	70	3	1.5
1/2	15	LESS UNION	4 1/2	114	6 1/4	159	1 1/4	32	2 3/4	70	3	1.5
3/4	20	SINGLE UNION	5 5/16	135	5 1/2	140	1 1/4	32	2 3/4	70	3	1.5
3/4	20	LESS UNION	4 7/8	121	5 1/2	140	1 1/4	32	2 3/4	70	3	1.5
1	25	SINGLE UNION	6 1/8	156	7 1/4	184	2	51	3 3/8	86	5	2.5
1	25	LESS UNION	5 3/4	146	7 1/4	184	2	51	3 3/8	86	5	2.5
1 1/4	32	SINGLE UNION	7 1/8	181	8	203	2	51	3 7/8	100	7	3.0
1 1/2	40	SINGLE UNION	9 1/8	232	10	254	2 1/2	64	5	127	13	6.0
2	50	SINGLE UNION	10 1/4	260	12	305	3	76	6 1/2	165	21	9.5

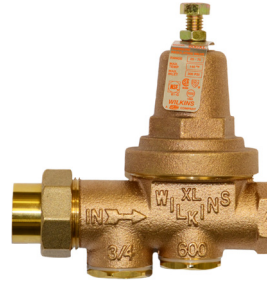

### Options

(Suffixes can be combined)

- standard with 20 mesh strainer screen, SU, FNPT
- HR - 75 psi to 125 psi spring range, factory set at 85 psi
- HLR - 10 psi to 125 psi spring range, factory set at 50 psi
- HTSTSC - 180°F maximum temp, stainless steel trim, spring, sealed cage
- C - copper sweat connection
- L - less integral by-pass check valve
- LU - less union assembly, female x female (3/4" & 1" only)
- LPV - 180°F maximum temp with 10 psi to 35 psi spring range, factory set at 20 psi
- SC - sealed cage bell housing and stainless steel adjustment screw
- 610XL - 400 psi inlet rating and 75 psi to 125 psi spring range, factory set at 85 psi
- CPVC - CPVC tailpiece connection (1/2" - 1")
- CH - Chrome stem & plunger
- P - tapped and plugged for gauge
- G - tapped and plugged with gauge

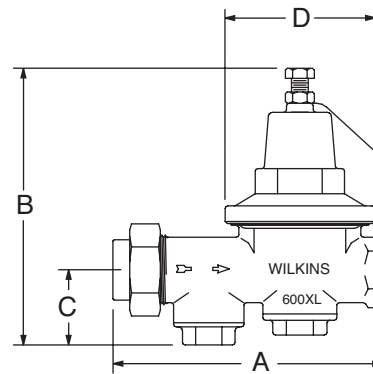

**MODEL 600XL 1/2" THRU 2" (STANDARD & METRIC)**

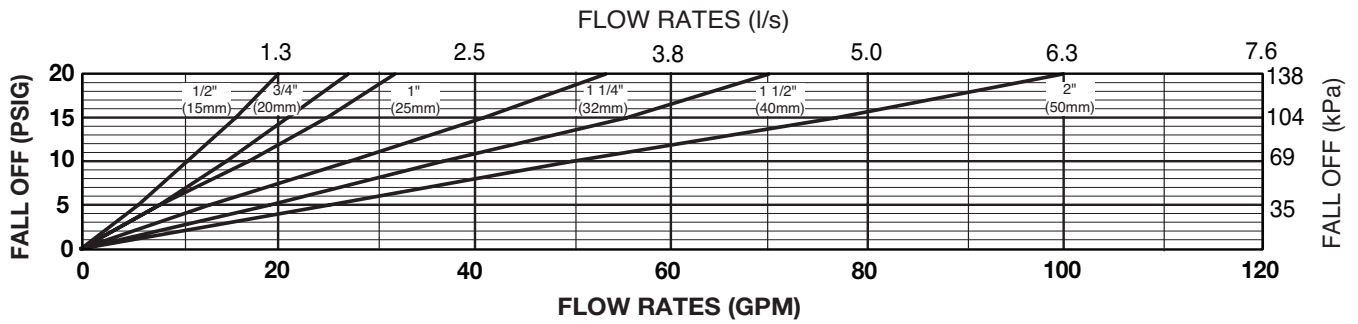

"Flow curves are based on a 50 psi pressure differential"

**Typical Installation**

Local codes shall govern installation requirements. Unless otherwise specified, the assembly shall be mounted in accordance with the latest edition of the Uniform Plumbing Code. The Model 600XL may be installed in any position. If installed in a pit, vault or inside application, specify the "SC" sealed cage option. Multiple installations are recommend for wide demand variations or where the desired pressure reduction is more than 4 to 1 (i.e.: 200 psi inlet reduced to 50 psi outlet). **CAUTION:** Anytime a reducing valve is adjusted, a pressure gauge must be used downstream to verify correct pressure setting. Do not bottom adjustment bolt on bell housing.

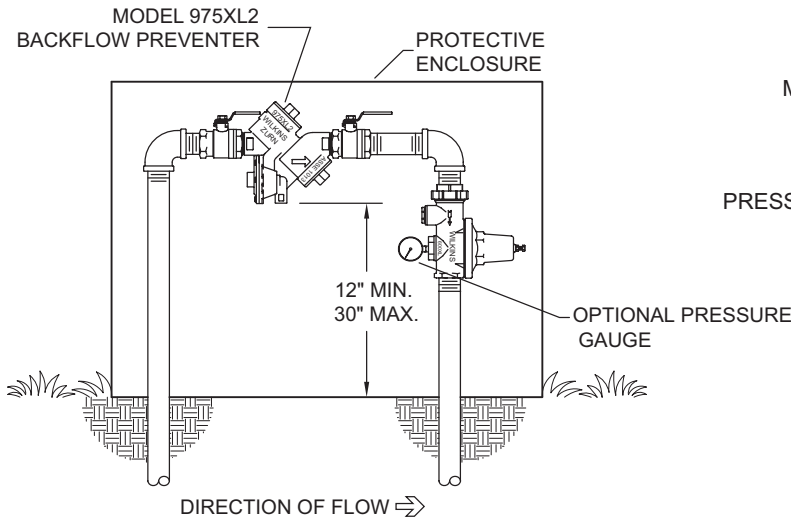

**OUTDOOR INSTALLATION**

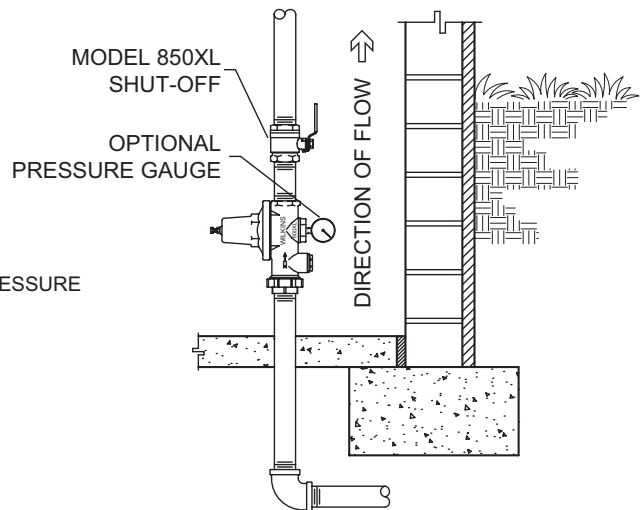

**VERTICAL INSTALLATION**

**Specifications**

The Pressure Reducing Valve shall be certified to NSF/ANSI/CAN 61, consist of a low lead bronze body and bronze bell housing, shall have separate access covers for the plunger and strainer screen and shall have a bolt to adjust the downstream pressure. The Pressure Reducing Valve shall be of the balanced piston design and shall reduce pressure in both flow and no-flow conditions. The bronze bell housing and access caps shall be threaded to the body and shall not require the use of ferrous screws. The Pressure Reducing Valve shall be a ZURN WILKINS Model 600XL.